

Components of Optical Instruments

Optical spectroscopic methods are based upon six phenomena:

1. Absorption
2. Fluorescence
3. Phosphorescence
4. Scattering
5. Emission
6. Chemiluminescence

Although the instruments for measuring each differ somewhat in configuration, most of their basic components are remarkably similar.

Components of typical spectroscopic instruments:

1. A stable source of radiant energy (sources of radiation).
2. A transparent container for holding the sample (sample cell).
3. A device that isolates a restricted region of the spectrum for measurement (wavelength selector, monochromator or grating).
4. A radiation detector, which converts radiant energy to a usable electrical signal.
5. A signal processor and readout, which displays the transduced signal.

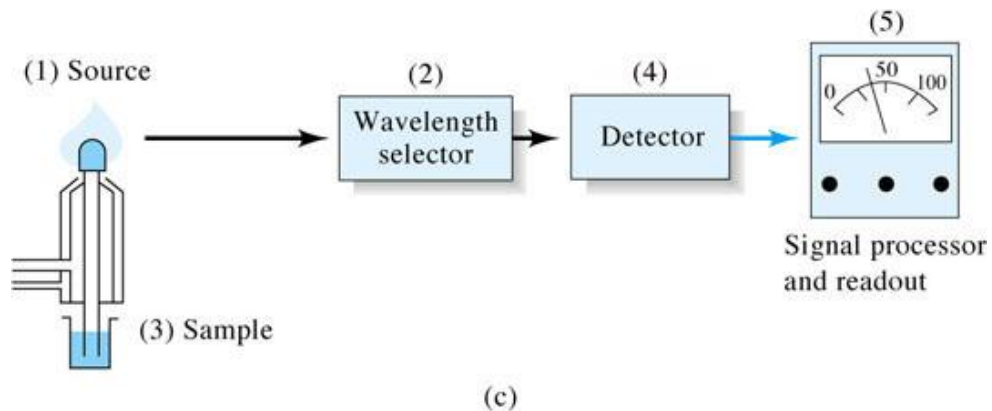
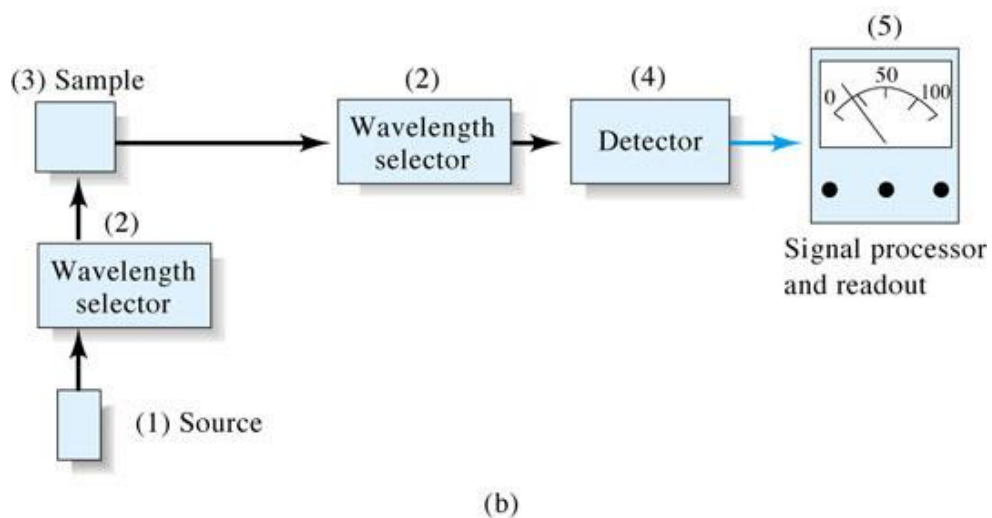
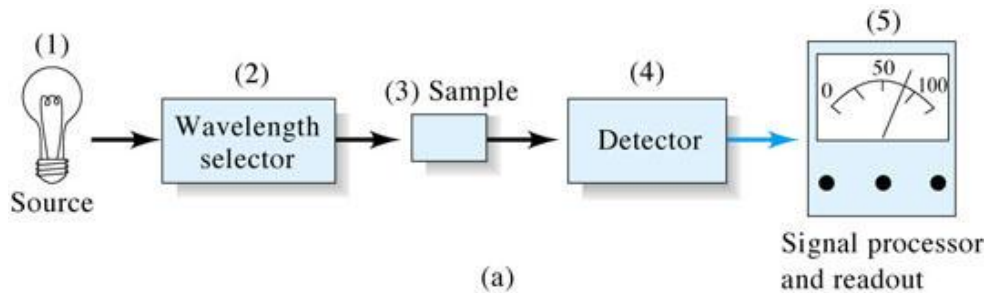

FIGURE 7-1 Components of various types of instruments for optical spectroscopy.

(a) the arrangement for *absorption* measurements. Note that source radiation of the selected wavelength is sent through the sample, and the transmitted radiation is measured by the detector-signal processing-readout unit. With some instruments, the position of the sample and wavelength selector is reversed.

(b), the configuration for *fluorescence* measurements. Here, two wavelength selectors are needed to select the excitation and emission wavelengths. The selected source radiation is incident on the sample and the radiation emitted is measured, usually at right angles to avoid scattering.

(c), the configuration for *emission* spectroscopy is shown. Here, a source of thermal energy, such as a flame or plasma, produces an analyte vapor that emits radiation isolated by the wavelength selector and converted to an electrical signal by the detector.

Wavelength, nm 100 200 400 700 1000 2000 4000 7000 10,000 20,000 40,000

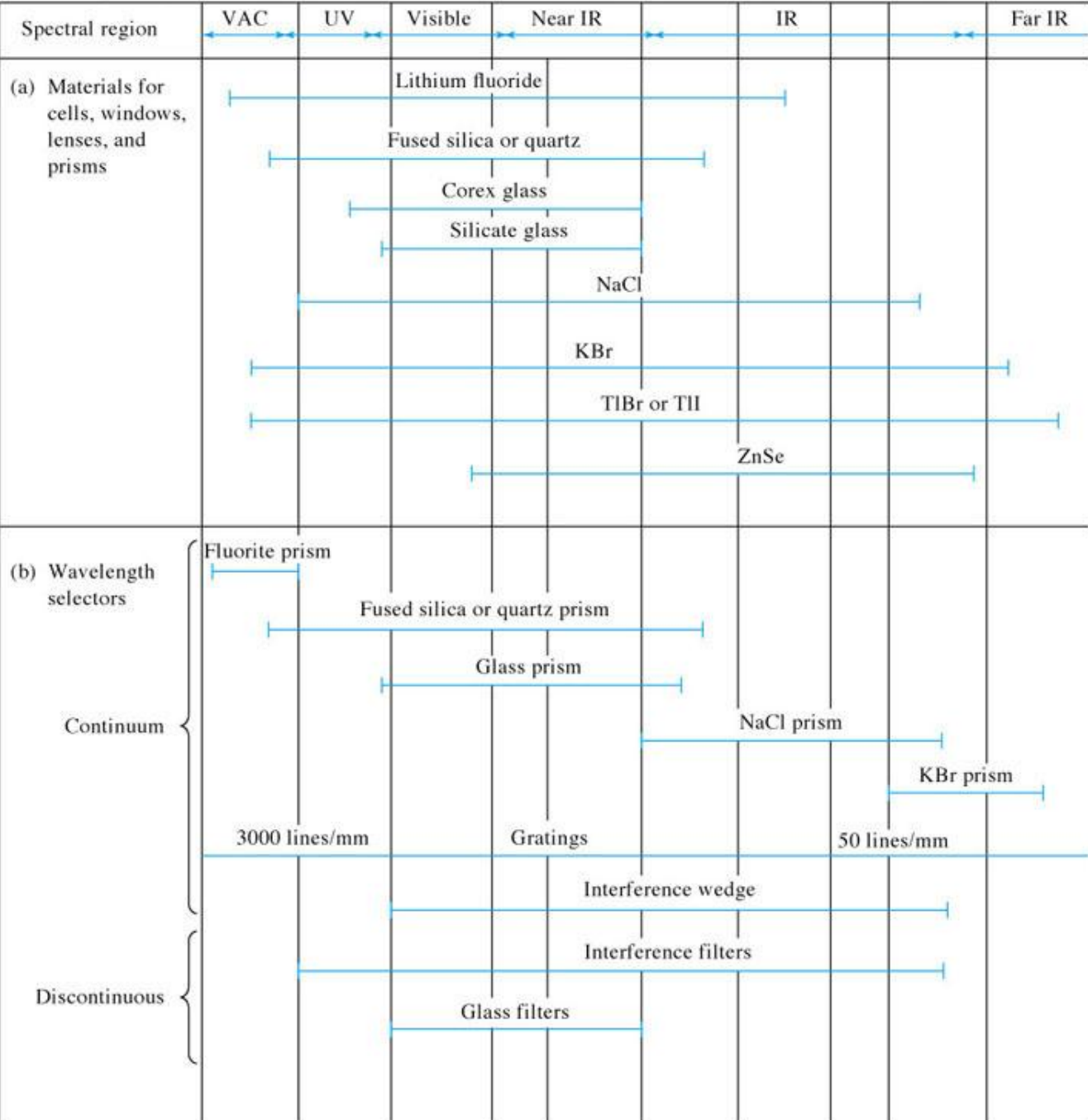

Figures 7-2 and 7-3 summarize the optical characteristics of all the components shown in Figure 7-1 with the exception of the signal processor and readout.

Figures 7-2

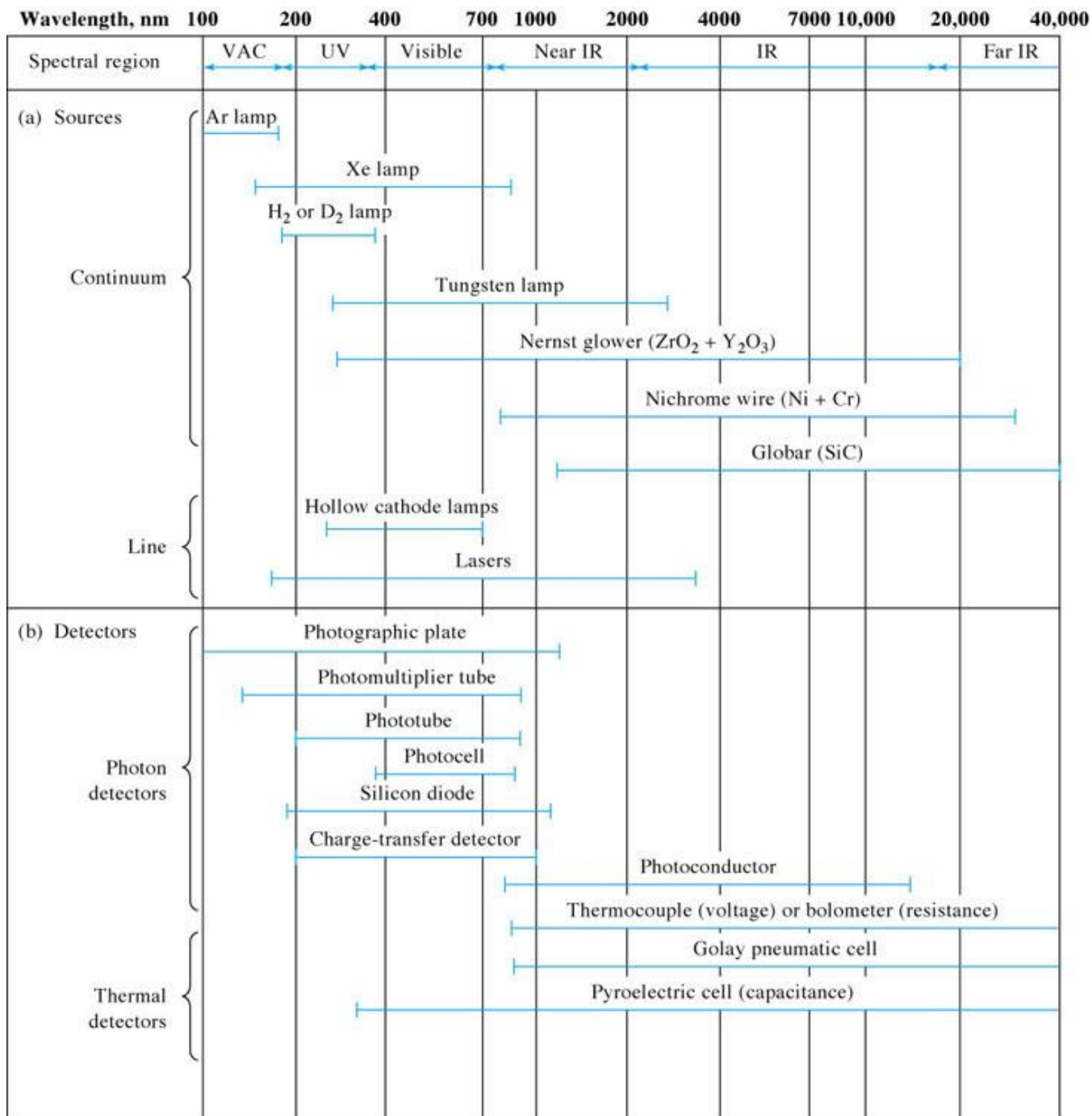

Figures 7-3

Sources of Radiation

- * In order to be suitable for spectroscopic studies, a source
 - must generate a beam of radiation with sufficient power for easy detection and measurement,
 - output power should be stable for reasonable periods.

- * Sources are of two types.
 1. Continuum sources
 2. Line Sources

Continuum Sources:

- Continuum sources emit radiation that changes in intensity only slowly as a function of wavelength. It is widely used in absorption and fluorescence spectroscopy. For the ultraviolet region, the most common source is the deuterium lamp. High pressure gas filled arc lamps that contain argon, xenon, or mercury serve when a particular intense source is required. For the visible region of the spectrum, the tungsten filament lamp is used universally. The common infrared sources are inert solids heated to 1500 to 2000 K.

Continuum Source

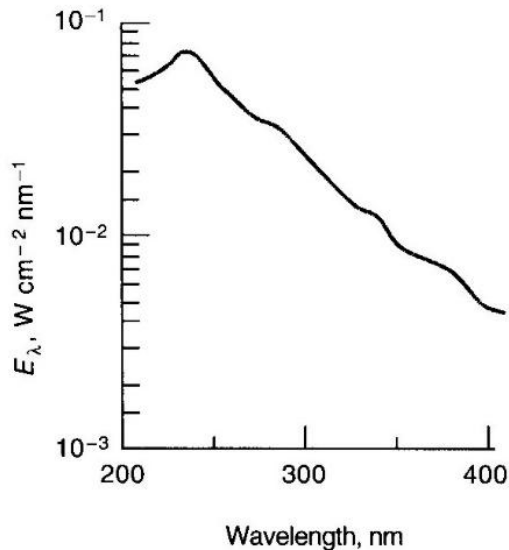

FIGURE 7-13 Output from a deuterium lamp.

Line Sources:

Sources that emit a few discrete lines find wide use in atomic absorption spectroscopy, atomic and molecular fluorescence spectroscopy, and Raman spectroscopy. Mercury and sodium vapor lamps provide a relatively few sharp lines in the ultraviolet and visible regions and are used in several spectroscopic instruments. Hollow cathode lamps and electrodeless discharge lamps are the most important line sources for atomic absorption and fluorescence methods.

Line Source

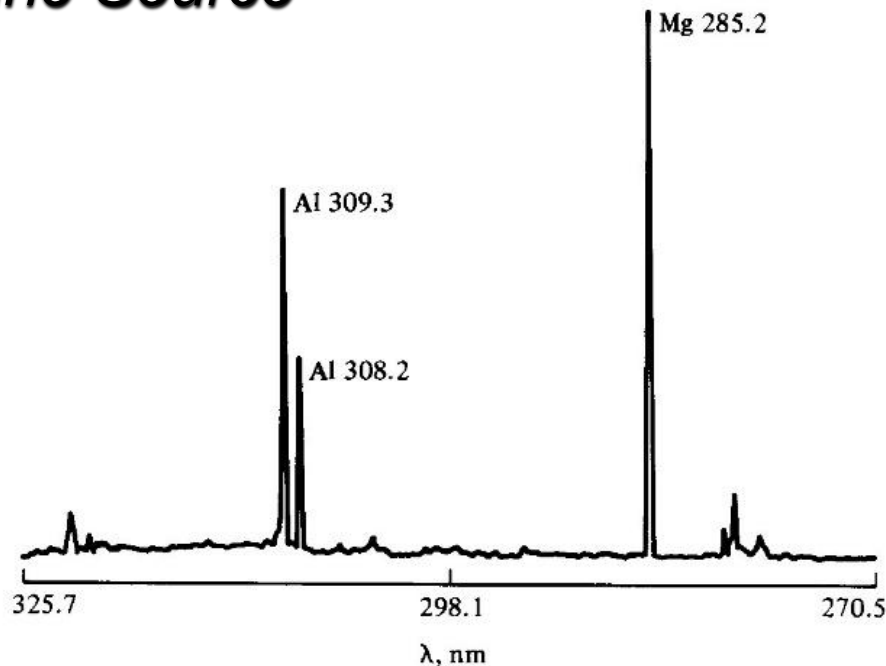

FIGURE 4-8 Portion of spectrum from a dual-element hollow cathode lamp.

Laser Sources

- * The term 'LASER' is an acronym for **L**ight **A**mplification by **S**timulated **E**mission of **R**adiation.
- * The first laser was introduced in 1960 and since then too many, highly important applications of lasers in chemistry were described.
- * Lasers are highly useful because of their
 - very high intensities,
 - narrow bandwidths,
 - single wavelength, and
 - coherent radiation.
- * Lasers are widely used in high-resolution spectroscopy.

Components of Lasers:

The important components of laser source are

- lasing medium,
- pumping source, and
- mirrors.

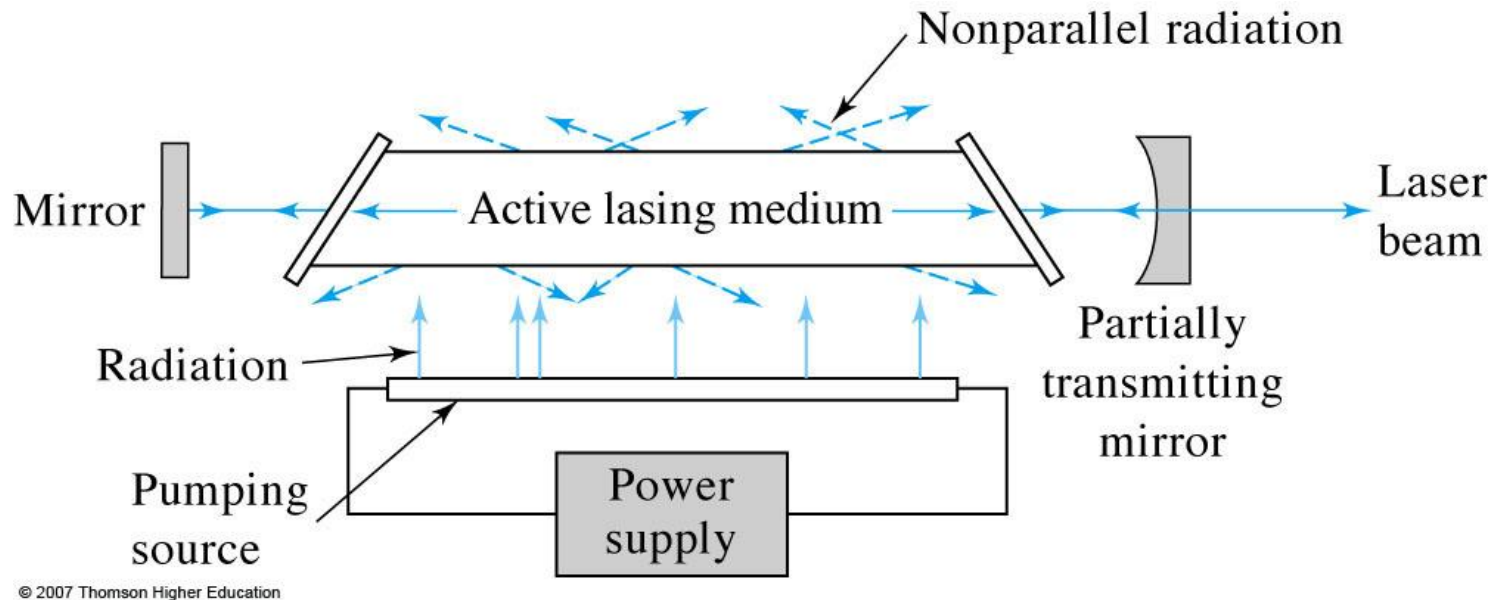

Figure 7-4. Schematic representation of a typical laser source.

The heart of the device is the lasing medium. It may be a solid crystal such as ruby, a semiconductor such as gallium arsenide, a solution of an organic dye or a gas such as argon or krypton.

Four processes in Lasing Mechanism:

1. Pumping
2. Spontaneous emission (fluorescence)
3. Stimulated emission
4. Absorption

1. Pumping

- Molecules of the active medium are excited to higher energy levels
- Energy for excitation \rightarrow electrical current, intense radiant source, or chemical reaction

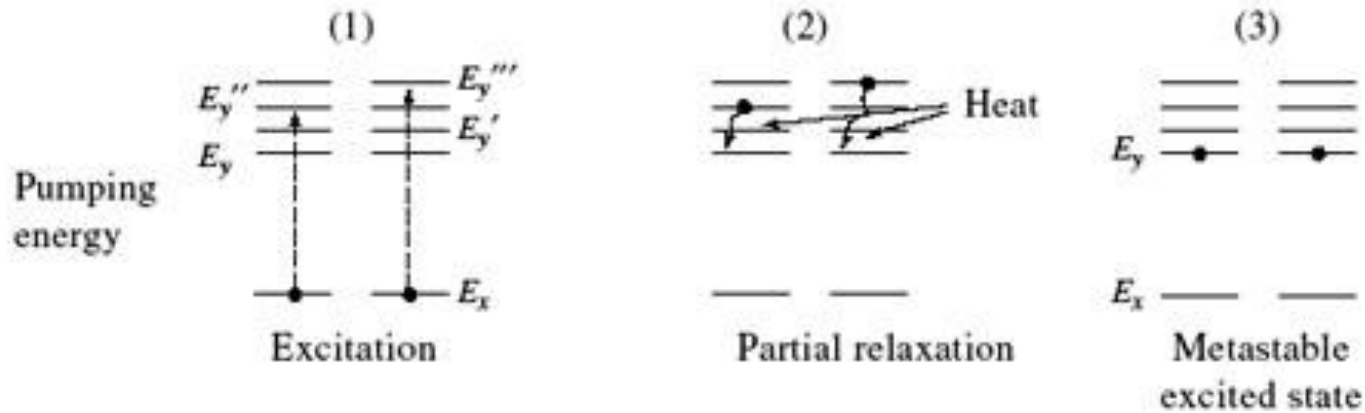

(a) Pumping (excitation by electrical, radiant, or chemical energy)

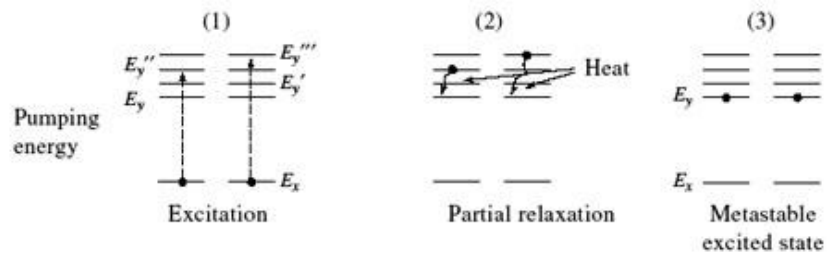

(a) Pumping (excitation by electrical, radiant, or chemical energy)

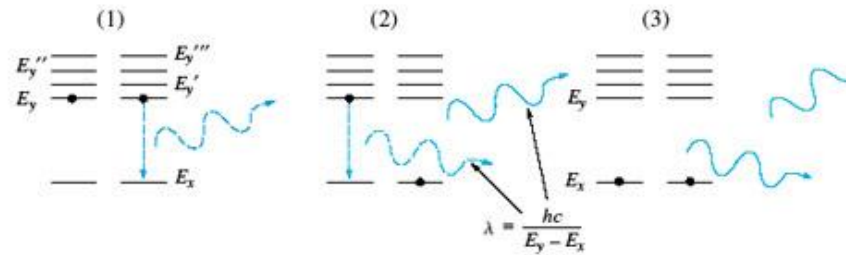

(b) Spontaneous emission

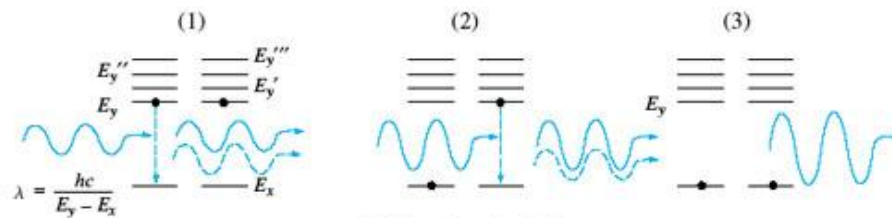

(c) Stimulated emission

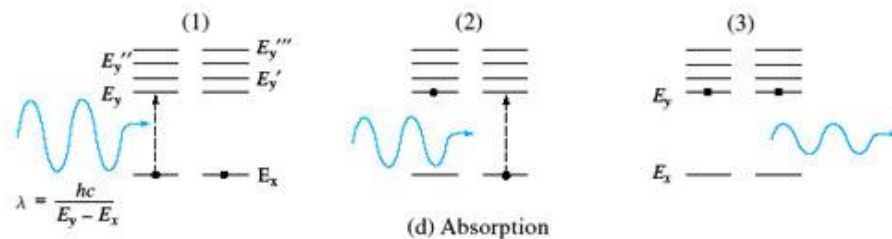

(d) Absorption

2. Spontaneous Emission

- A molecule in an excited state can lose excess energy by emitting a photon (this is fluorescence)
- $E = h\nu = hc/\lambda$; $E = E_y - E_x$
- E (fluorescence) < E (absorption) →
 λ (fluorescence) > λ (absorption) [fluorescent light is at longer wavelength than excitation light]

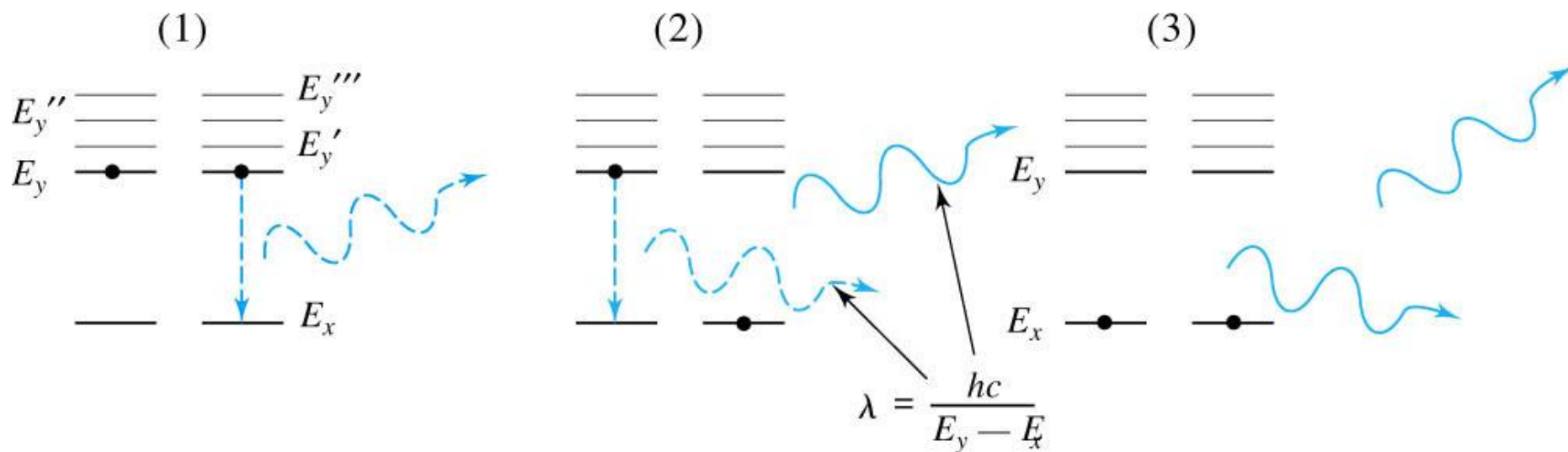

(b) Spontaneous emission

3. Stimulated Emission

- *Must have stimulated emission to have lasing*
- *Excited molecules interact with photons that have precisely the same energies produced by spontaneous emission*
- *Collision causes excited molecules to relax and emit a photon (i. e., emission)*
- *Photon energy of this emission = photon energy of collision photon → now there are 2 photons with same energy (in same phase and same direction)*

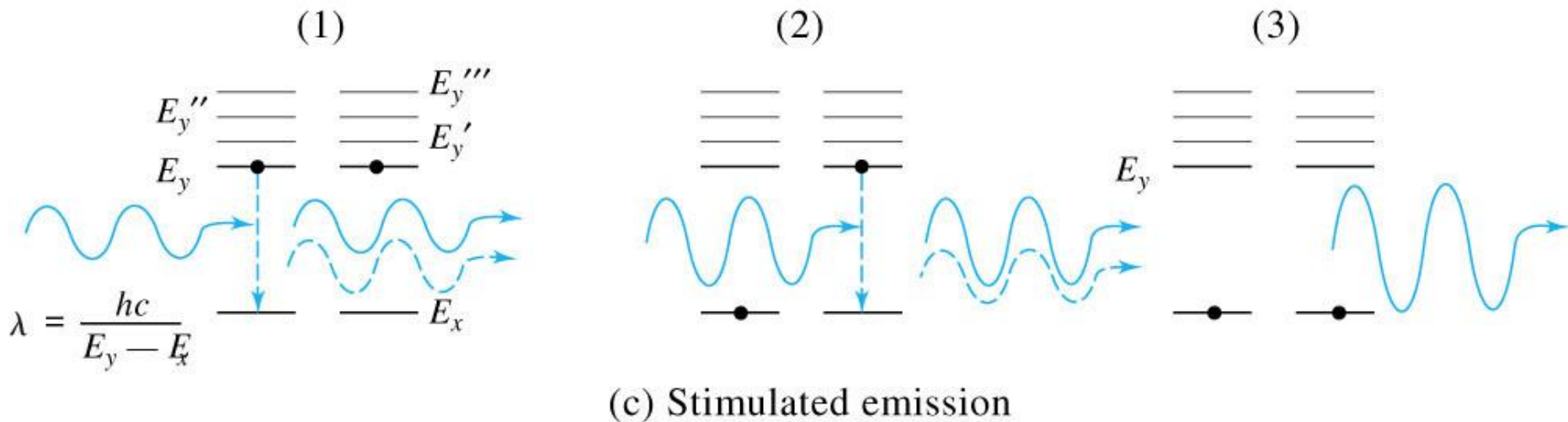

4. Absorption

- Competes with stimulated emission
- A molecule in the ground state absorbs photons and is promoted to the excited state
- Same energy level as pumping, but now the photons that were produced for lasing are gone

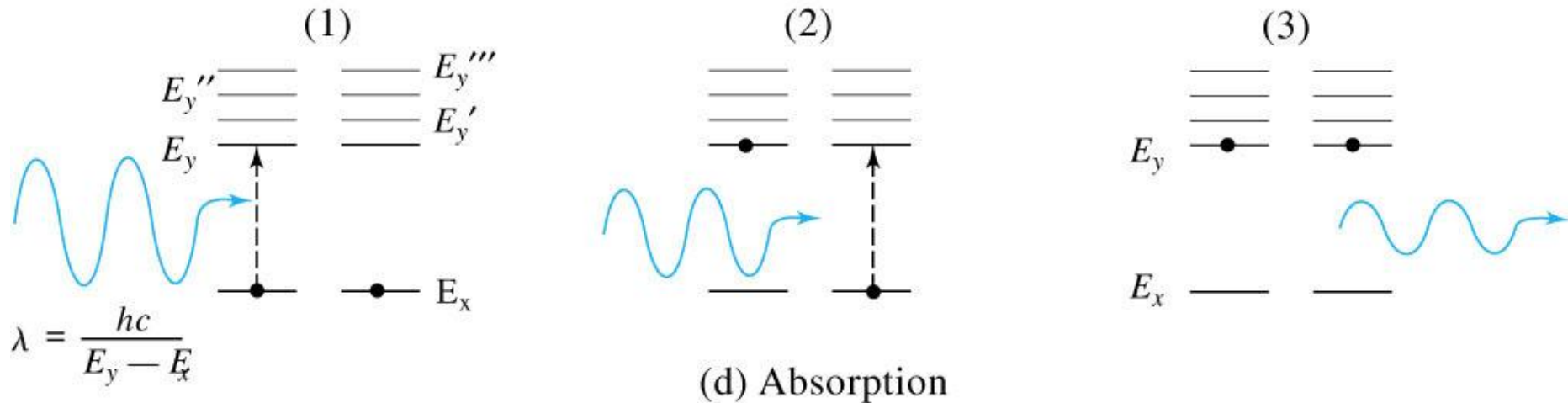

Population Inversion:

- To have light amplification in a laser, the number of photons produced by stimulated emission must exceed the number lost by absorption.
- *Must have population inversion to sustain lasing.*
- *Population of molecules is inverted (relative to how the population normally exists).*
- *Normally: there are more molecules in the ground state than in the excited state (need > 50 %).*
- *Population inversion: More molecules in the excited state than in the ground state.*

Why is it important?

- *More molecules in the ground state → more molecules that can absorb photons*
- *Remember: absorption competes with stimulated emission*
- *Light is attenuated rather than amplified*
- *More molecules in the excited state → net gain in photons produced*

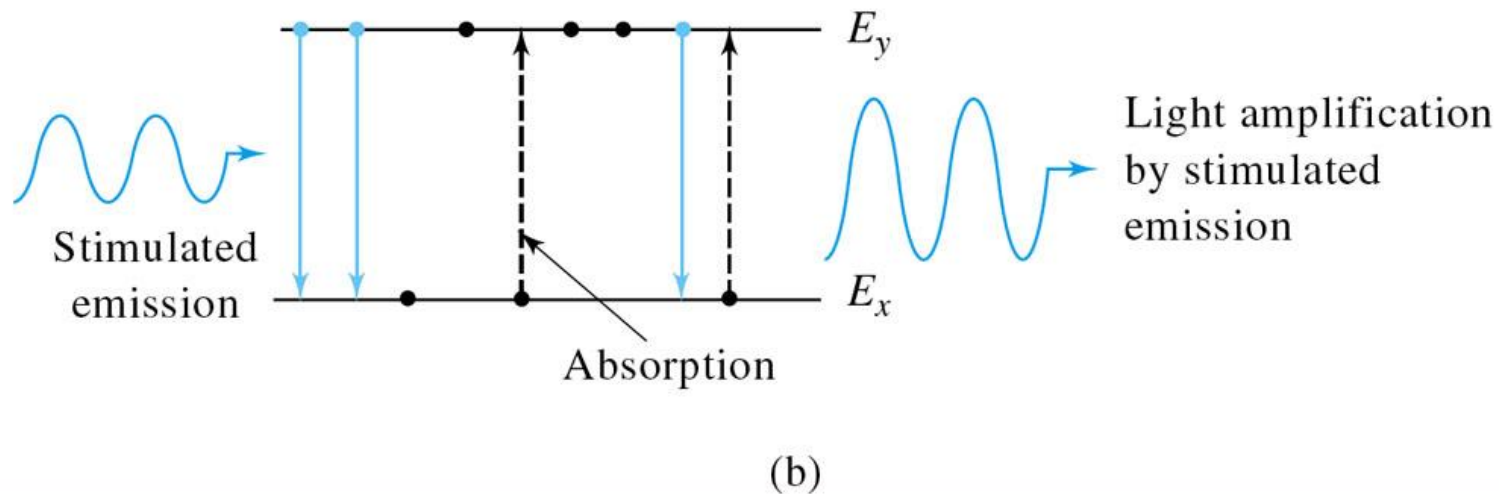
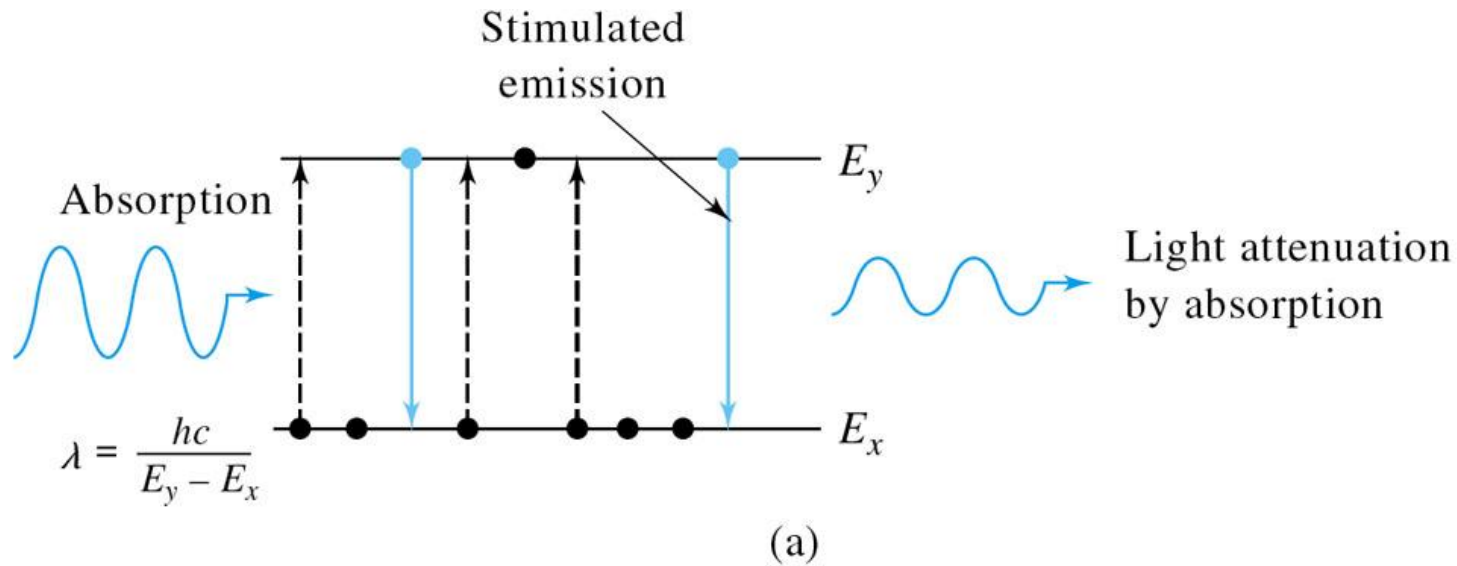
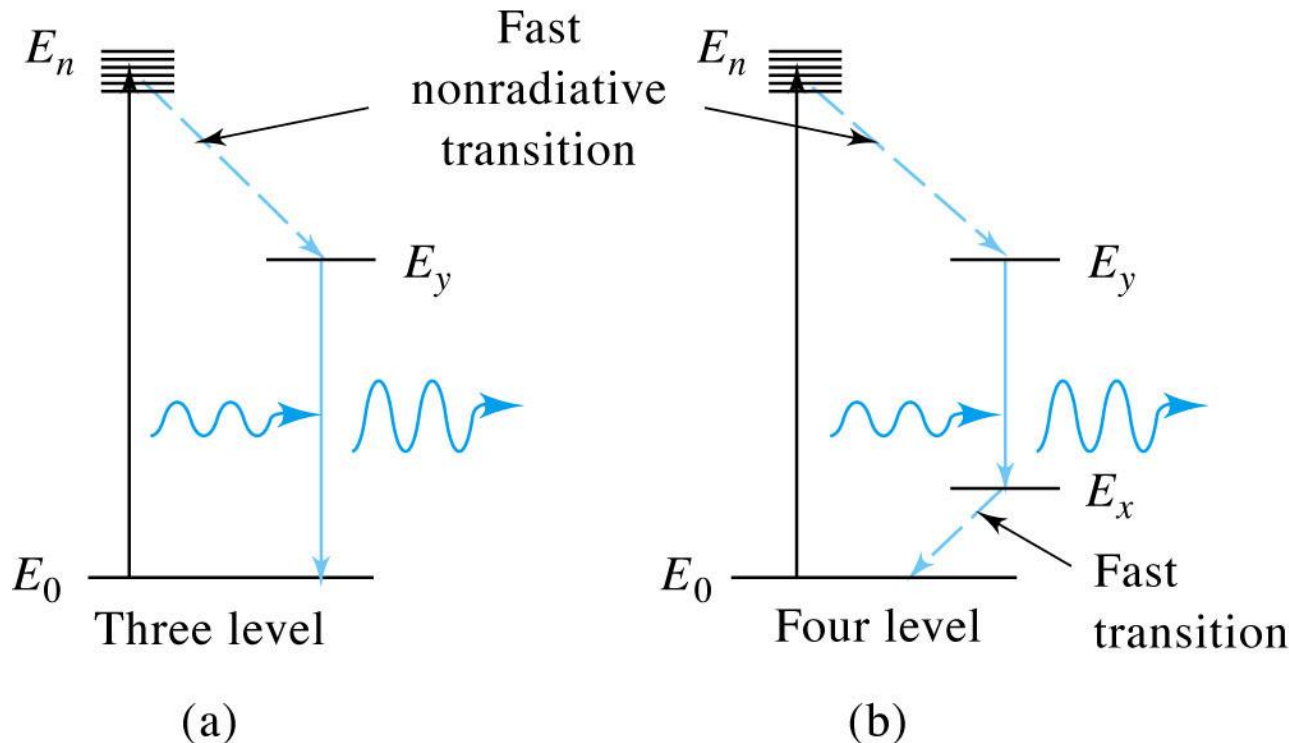

FIGURE 7-6 Passage of radiation through (a) a noninverted population and (b) an inverted population created by excitation of electrons into virtual states by an external energy source (pumping).

How to achieve population inversion?

- Laser systems: 3-level or 4-Level
- 4-level is better → easier to sustain population inversion
- 3-level system: lasing transition is between E_y (excited state) and the ground state
- 4-level system: lasing transition is between two energy levels (neither of which is ground state)



All you need is to have more molecules in E_y than E_x for population inversion (4-level system) → easier to achieve more molecules in E_y than ground state (3-level system)

Laser types :

- Solid state lasers
 - Nd:YAG [1064 nm: IR; 523 nm: green], cw/pulsed
 - The Nd- YAG laser is one of the most widely used solid-state lasers. The lasing medium consists of neodymium ion in a host crystal of yttrium aluminum garnet. This system offers the advantage of being a four level laser, which makes it much easier to achieve population inversion than with the ruby laser.
- Gas lasers:
 - He-Ne [632.8 nm: red], cw , Ar⁺ [488 nm (blue) or 514.5 nm (green)]; also UV lines, cw (4-level system]
 - Excimer lasers contain a gaseous mixture of helium, fluorine, and one of the rare gases argon, krypton, or xenon. The rare gas is electronically excited by a current followed by reaction with fluorine to form excited species such as ArF*, KrF*, or XeF* which are called *excimers* because they are stable only in the *excited* state. Because the eximer ground state is unstable, rapid dissociation of the compounds occurs as they relax while giving off a photon. Thus, there is a population inversion as long as pumping is carried on. Excimer lasers produce high-energy pulses in the ultraviolet (351 nm for XeF, 248 nm for KrF, and 193nm for ArF).
- Dye Lasers
 - Organic dye solutions → tunable outputs (various distinct λ s), pulsed (4-level system)

Wavelength Selectors

Need to select wavelengths (λ) of light for optical measurements. Ideally, the output from a wavelength selector would be a radiation of a single wavelength or frequency. No real wavelength selector approaches this ideal; instead, a band, such as that shown in Figure 7-11, is produced.

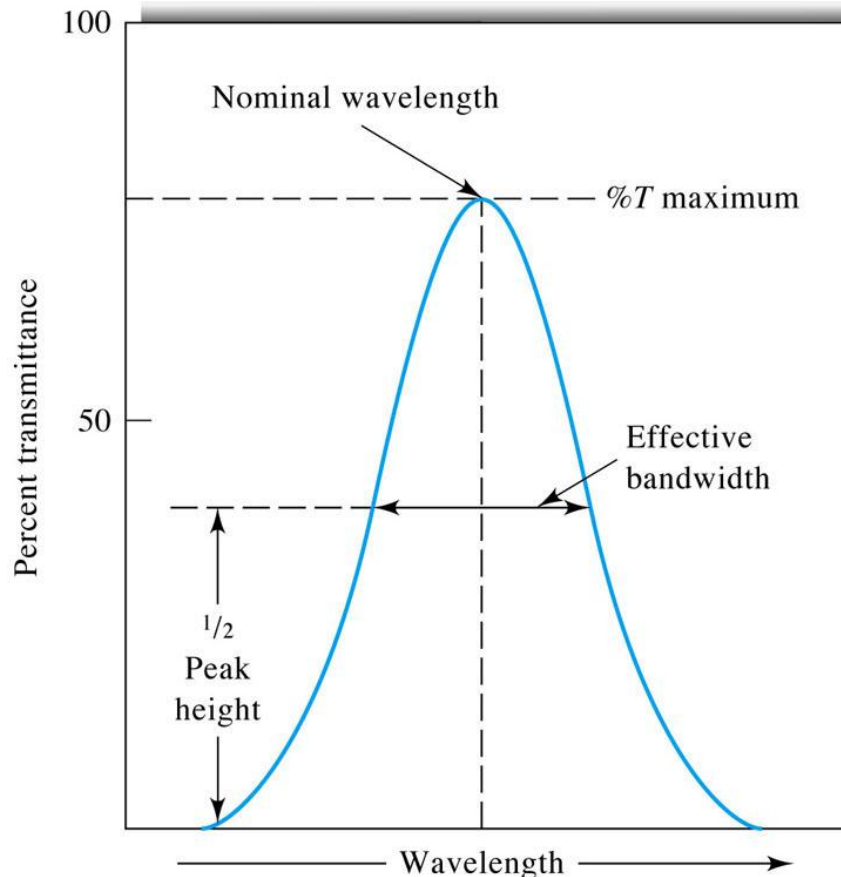

Here, the percentage of incident radiation of a given wavelength that is transmitted by the selector is plotted as a function of wavelength. The *effective bandwidth*, is an inverse measure of the quality of the device, a narrower bandwidth representing better performance.

Figure 7-11

Wavelength Selectors

- *There are two types of wavelength selectors:*
 - *FILTERS and*
 - *MONOCHROMATORS*
- *There are 3 types of filters:*
 - ** absorption filters*
 - ** interference filters*
 - ** cut-off filters (may be considered as absorption filter)*
- *2 types of dispersing elements can be used in a MC*
 - ** prism*
 - ** grating*

FILTERS

- *Simple, rugged (no moving parts in general)*
- *Relatively inexpensive*
- *Can select some broad range of wavelengths*
- *Most often used in ;*
 - *field instruments*
 - *simpler instruments*
 - *instruments dedicated to monitoring a single wavelength range.*

Interference Filters

- Dielectric layer between two metallic films
- Radiation hits filter \rightarrow some reflected, some transmitted (transmitted light reflects off bottom surface)
- If proper radiation $\lambda \rightarrow$ reflected light in phase w/incoming radiation: other λ undergo destructive interference
- i.e., λ s of interest \rightarrow constructive interference (transmitted through filter); unwanted λ s \rightarrow destructive interference (blocked by filter)
- Result: narrow range of λ s transmitted

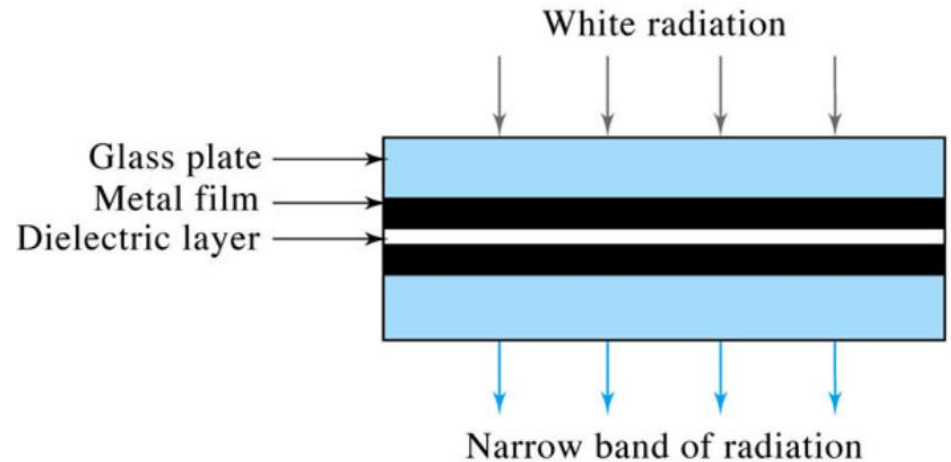

(a)

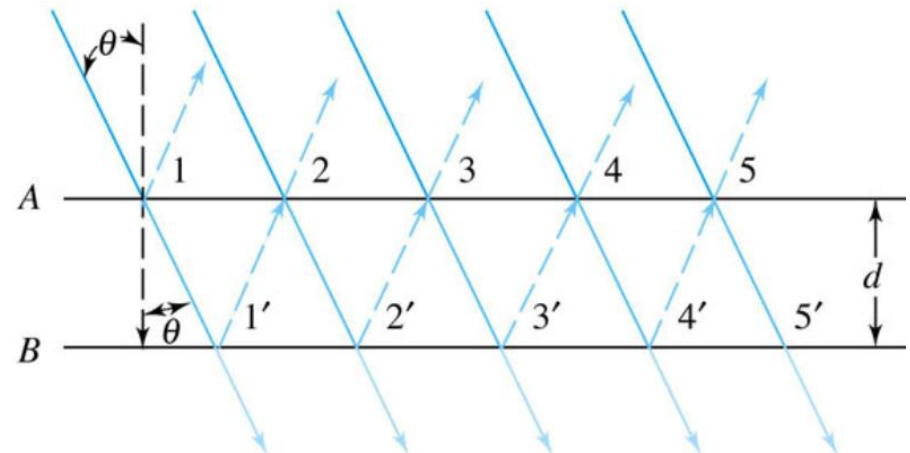

(b)

Interference Filters

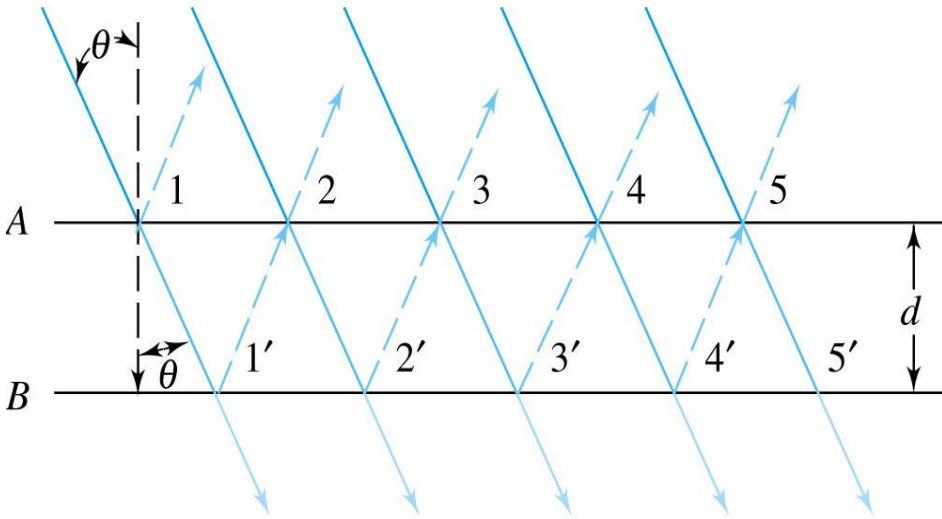

At point 1. the radiation is partially reflected and partially transmitted to point 1' where partial reflection and transmission again take place. The same process occurs at 2, 2', and so forth. For reinforcement to occur at point 2, the distance traveled by the beam reflected at 1' must be some multiple of its wavelength in the medium λ' . Because the path length between surfaces can be expressed as $d/\cos\theta$, the condition for reinforcement is that

d = thickness of dielectric
 n = order of interference (integer)
 λ = wavelength in dielectric
 λ' = wavelength in air
 η = refractive index of the dielectric

$$n\lambda' = 2d / \cos\theta$$

when $\theta \rightarrow 0$, $\cos\theta = 1$,

$$n\lambda' = 2d,$$

The corresponding wavelength in air is

$$\lambda = \lambda' \eta$$

$$\lambda = \frac{2dn}{n}$$

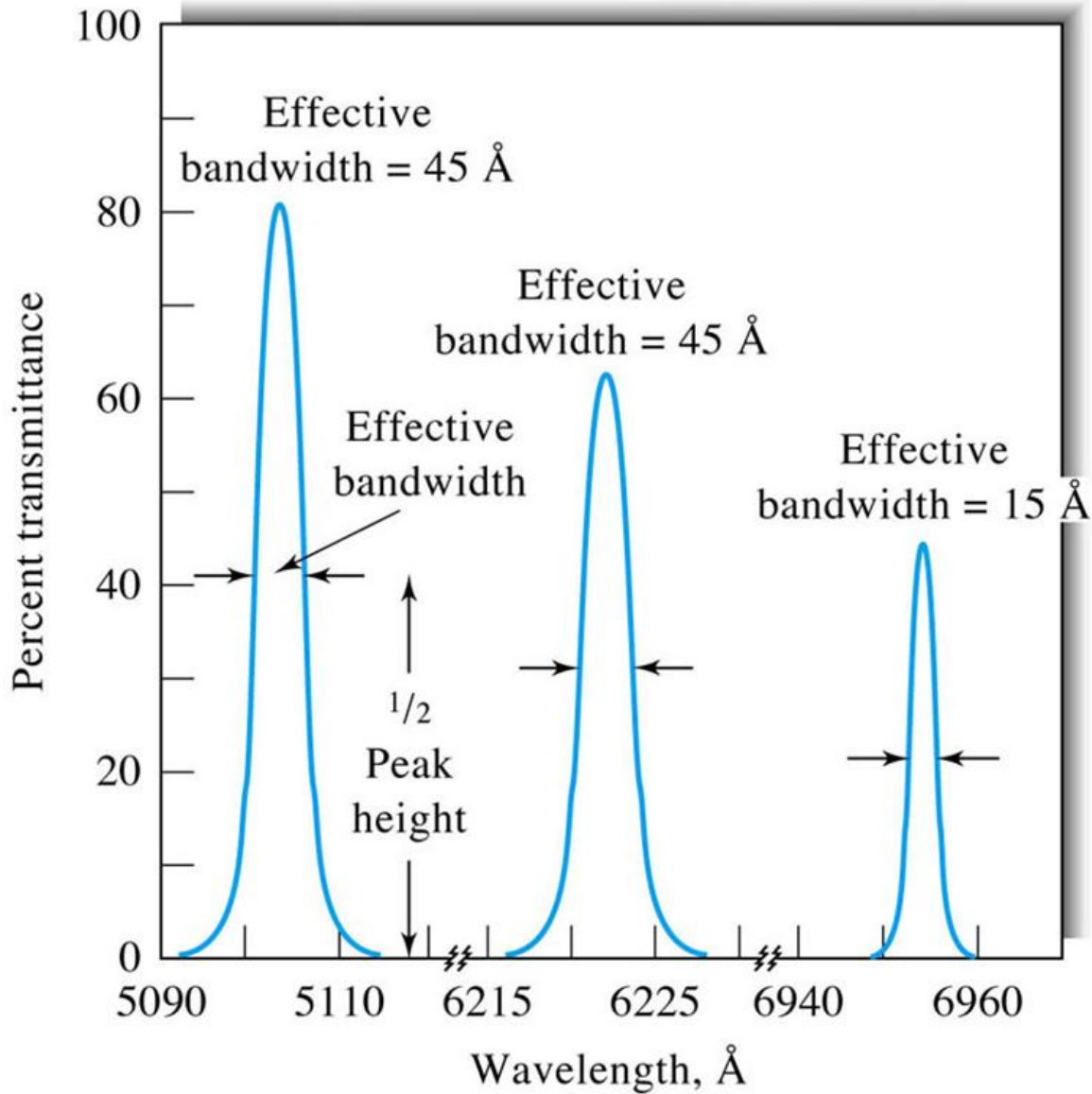
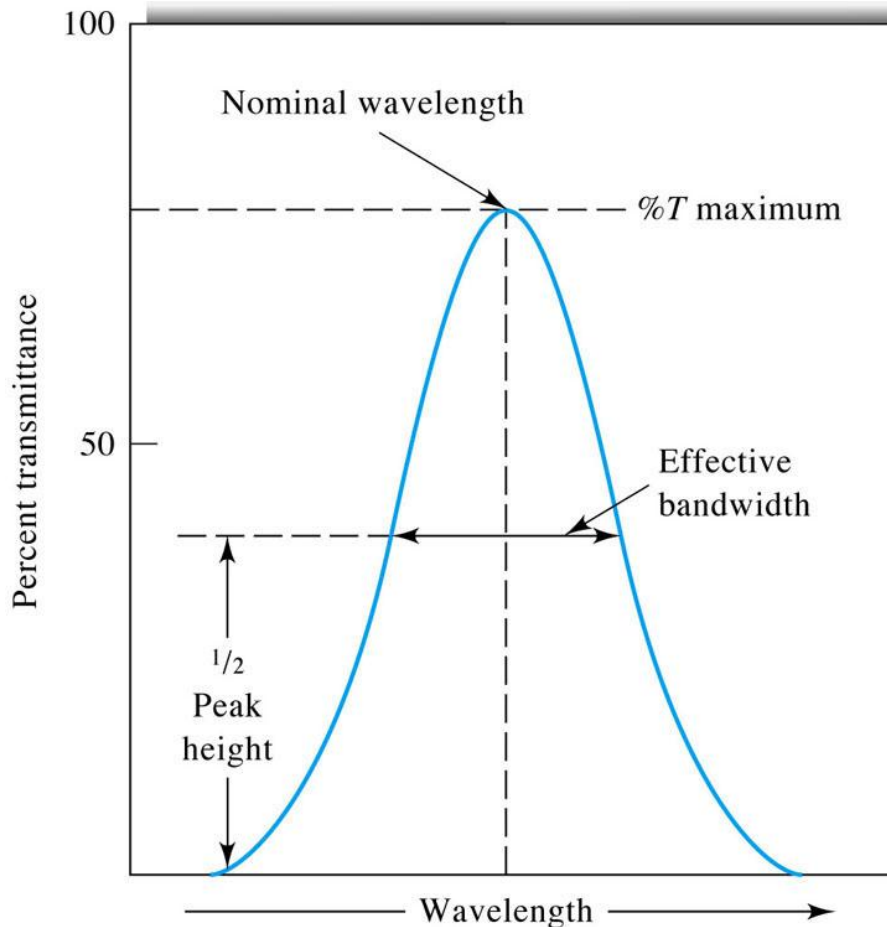

Figure 7-13 illustrates the performance characteristics of typical interference filters. Filters are generally characterized, as shown, by the wavelength of their transmittance peaks, the percentage of incident radiation transmitted at the peak and their effective bandwidths.

Absorption Filters

- This type of filters absorbs most incident wavelengths and transmits a band of wavelengths. Sometimes, they are called transmission filters. Absorption filters are cheap and can be as simple as colored glasses or plastics.



They transmit a band of wavelengths with an effective bandwidth in the range from 30-250 nm. Their transmittance is usually low where only about 10-20% of incident beam is transmitted.

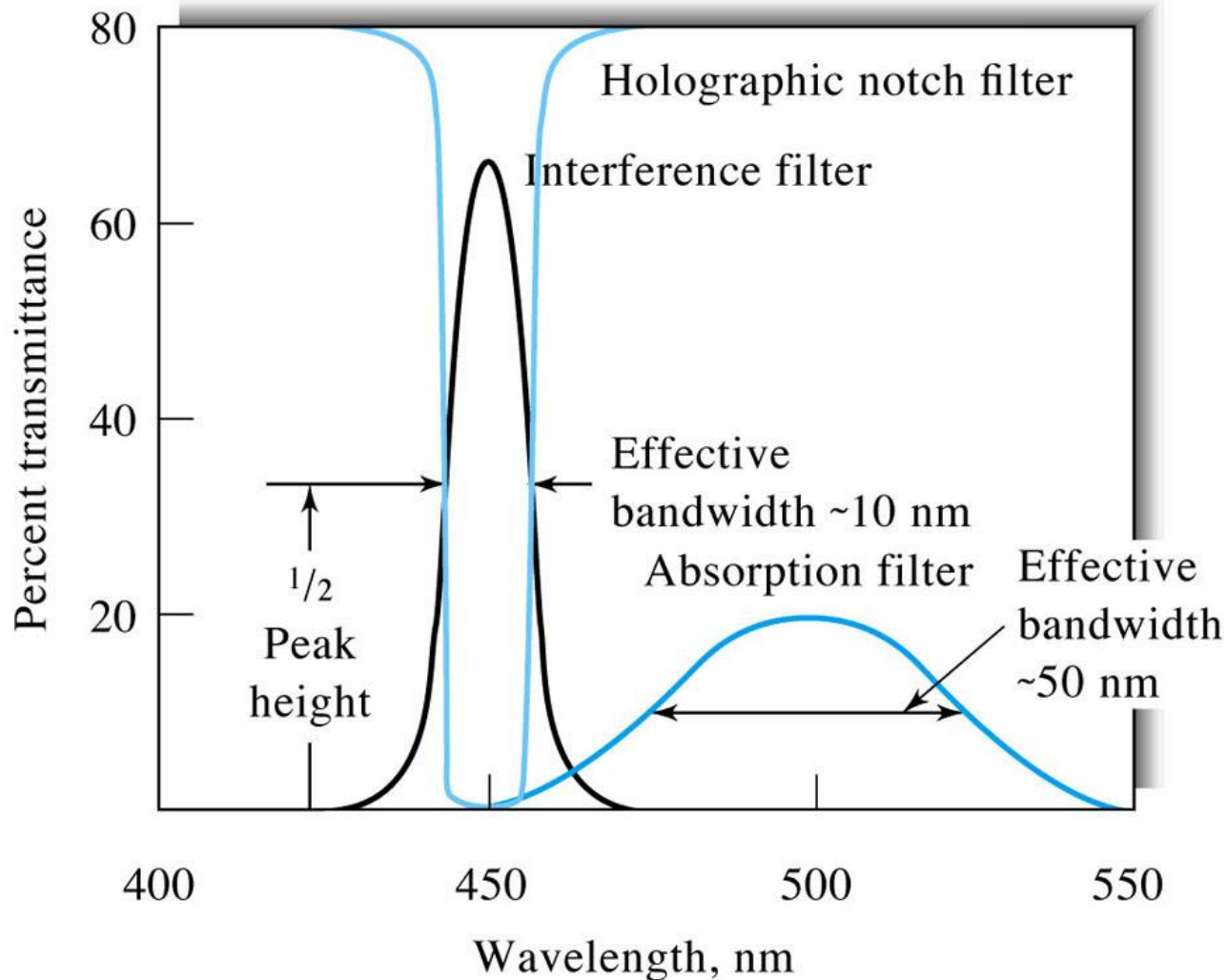

© 2007 Thomson Higher Education

Effective bandwidths of interference and absorption filters.

Cut-off (e.g., high-pass-low pass) filters

- Passes high wavelengths, blocks low wavelengths or vica versa.
- Type of filter could be used for emission or fluorescence (since excitation light is lower λ and should be blocked; emission is higher λ and should be collected).

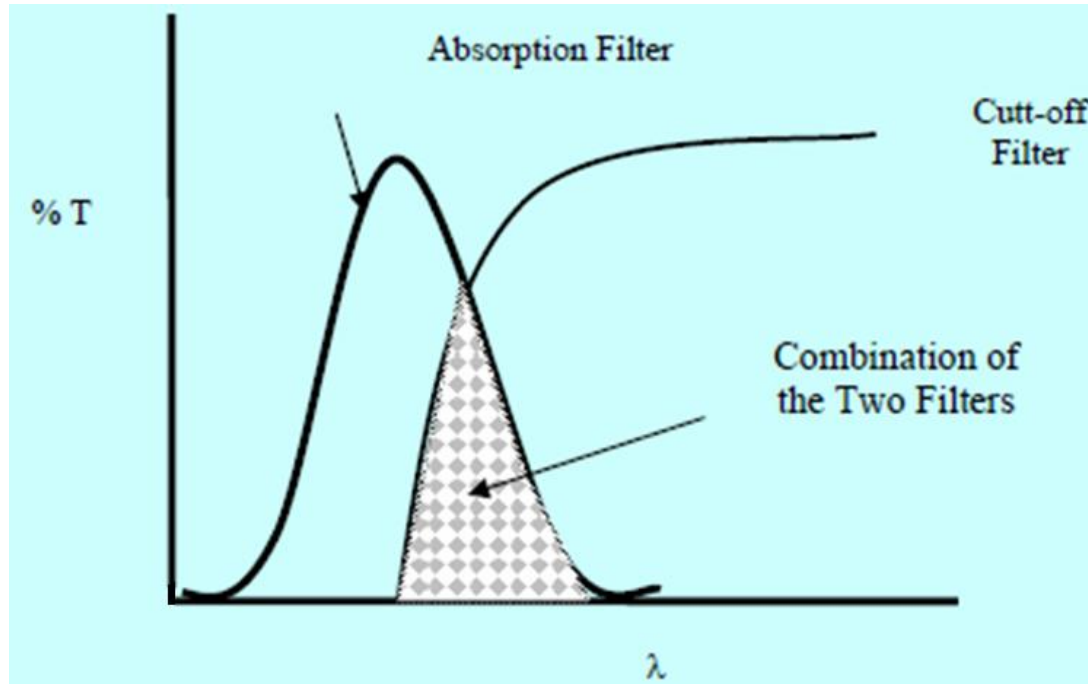

Usually, cut-off filters are not used as wavelength selectors but rather in combination of absorption filters to decrease the bandwidth of the absorption filter or to overcome problems of orders. Only the combination of the two filters (common area) will be transmitted which has much narrower effective bandwidth than absorption filters alone.

Monochromators

- *For many spectroscopic methods, it is necessary or desirable to be able to continuously vary the wavelength of radiation over a broad range. This process is called scanning a spectrum.*
- *Monochromators are designed for spectral scanning. Monochromators for ultraviolet, visible, and infrared radiation are all similar in mechanical construction in the sense that they use slits, lenses, mirrors, windows, and gratings or prisms.*
- *The materials from which these components are fabricated depend on the wavelength region of intended use.*

Prism Monochromators

- Prisms can be used to disperse ultraviolet, visible, and infrared radiation.
- the two most common types of prism designs: **Cornu type**, **Littrow type**

Cornu Prism

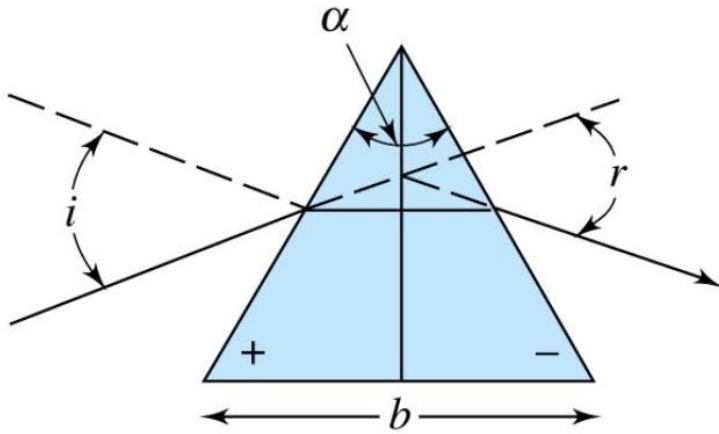

Cornu type

It is a 60° prism which is made either from glass or quartz. When quartz is used, two 30° prisms (one should be left handed and the other is right handed) are cemented together in order to get the 60° prism. This is necessary since natural quartz is optically active and will rotate light either to right or left hand. Cementing the left and right handed prisms will correct for light rotation and will transmit the beam in a straight direction

Littrow Prism

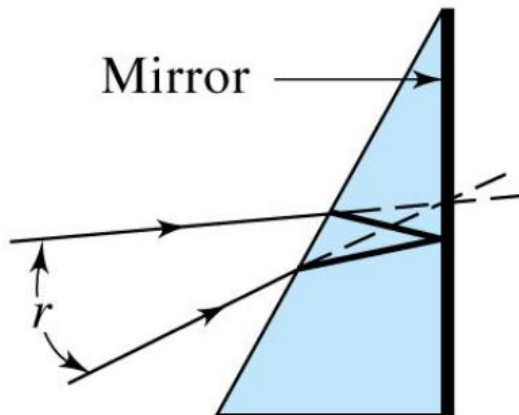

-Littrow type

A littrow prism is a 30° prism which uses the same face for input and dispersed radiation. The beam is reflected at the face perpendicular to base, due to presence of a fixed mirror. A littrow prism would be used when a few optical components are required

Monochromators:

- Entrance slit
- Collimating lens or mirror
- Dispersion element (prism or grating)
- Focusing lens or mirror
- Exit slit

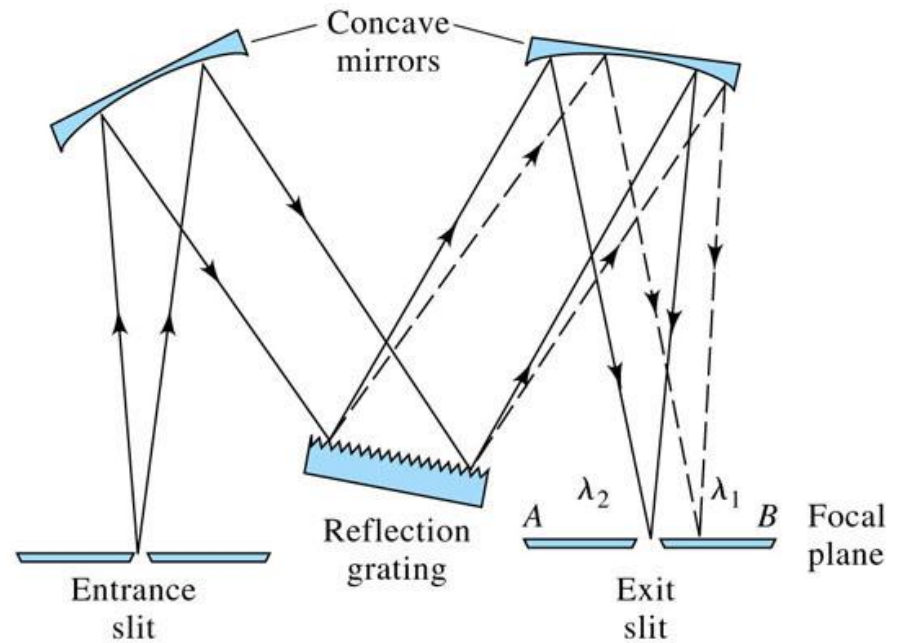

(a)

Reflection Gratings

- Light hits grating and dispersed
- Tilt grating to vary which wavelength passed at exit slit during the scan

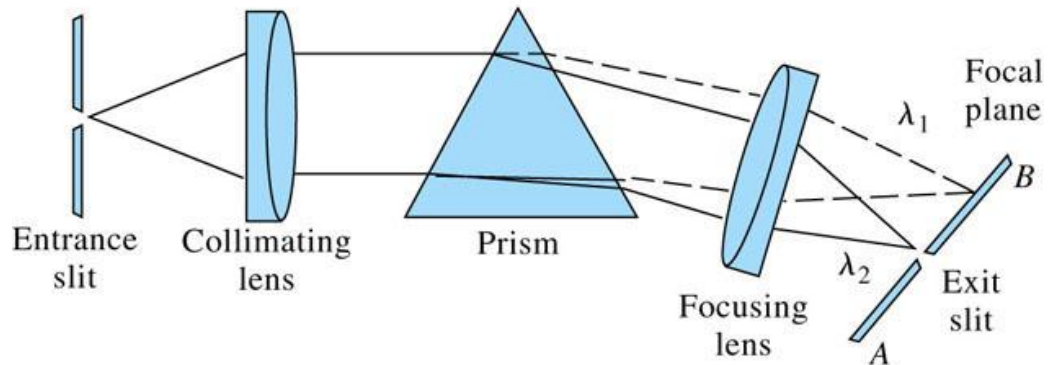

(b)

© 2007 Thomson Higher Education

FIGURE 7-18 Two types of monochromators: (a) Czerny-Turner grating monochromator and (b) Bunsen prism monochromator.

Grating Monochromators

- Currently, nearly all commercial monochromators are based on reflection gratings because they are:

- cheaper to fabricate,
- provide better wavelength separation for the same size dispersing element, and
- disperse radiation linearly along the focal plane.

- *linear dispersion* means that the position of a band along the focal plane varies linearly with its wavelength.

-

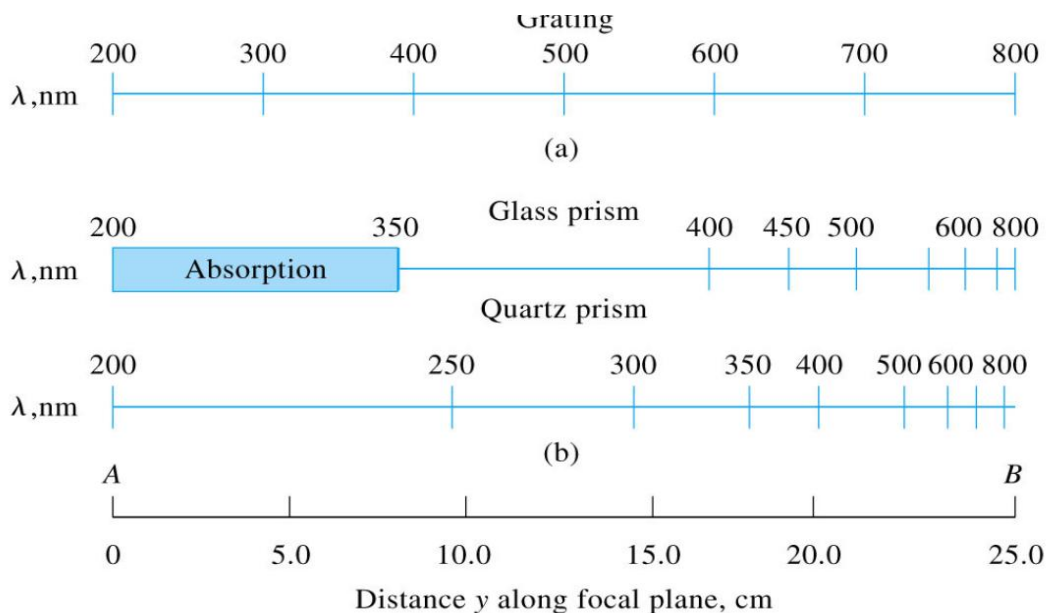

-For prism instruments, shorter wavelengths are dispersed to a greater degree than are longer ones, which complicates instrument design.

Echelle Gratings: Typical echellette gratings contain from 300 to 2000 lines/mm but an average line density of about 1200 to 1400 lines/mm is most common. The echellette grating *uses the long face for dispersion of radiation*. It is the grating of choice for molecular spectroscopic instruments.

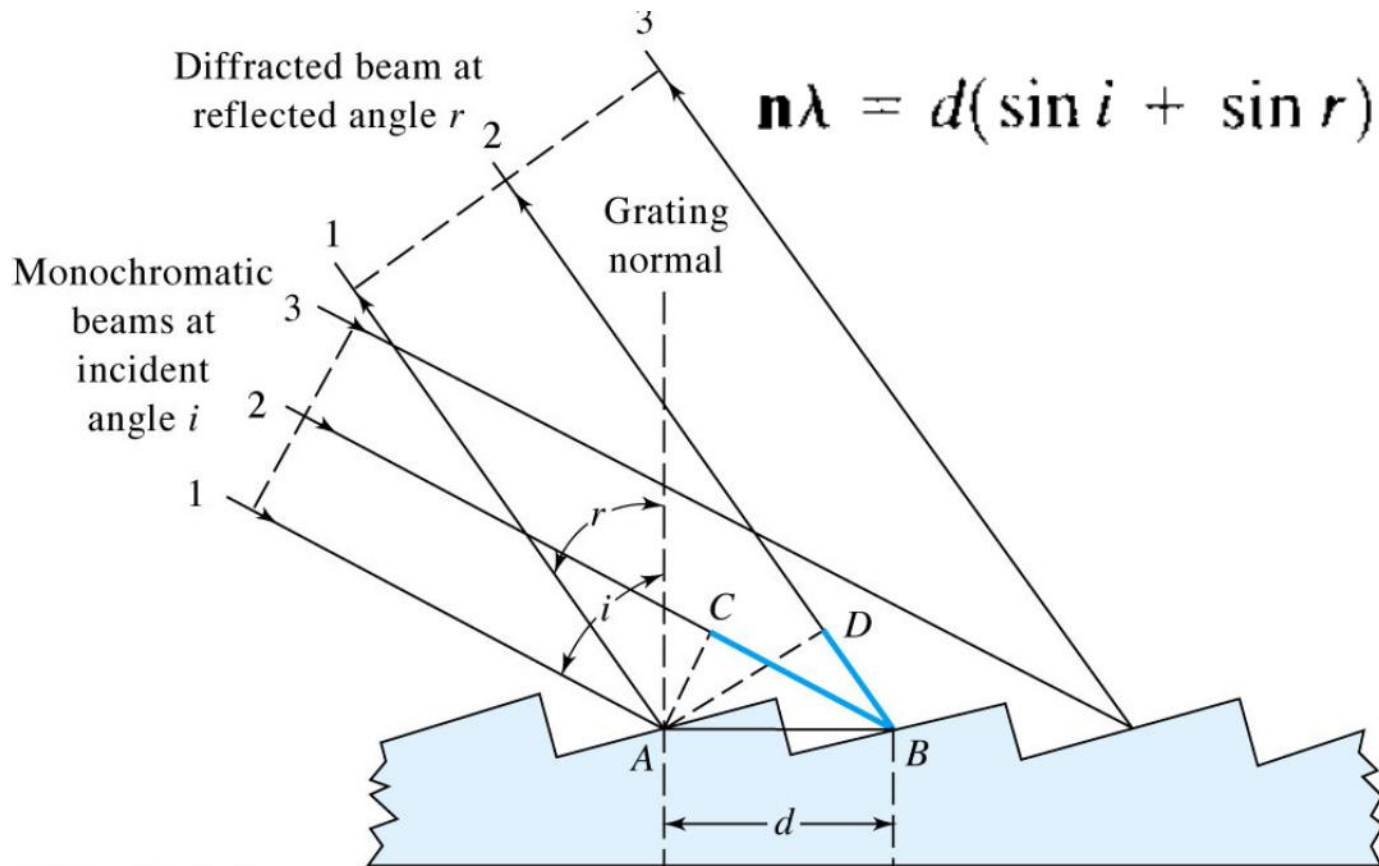

*Echelle Gratings: These have relatively coarse grooves (~80-300 lines/mm). They use the **short face for dispersion of radiation** and are characterized by very high dispersion ability.*

$$r \approx i = \beta$$

$$n\lambda = 2d \sin \beta$$

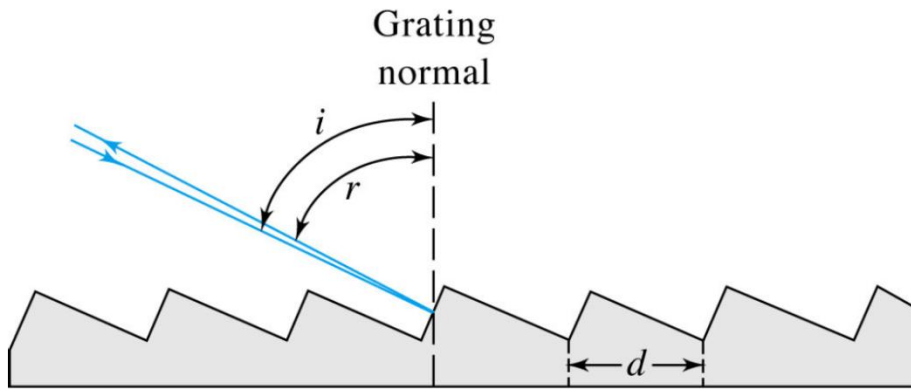

Echelle Monochromator

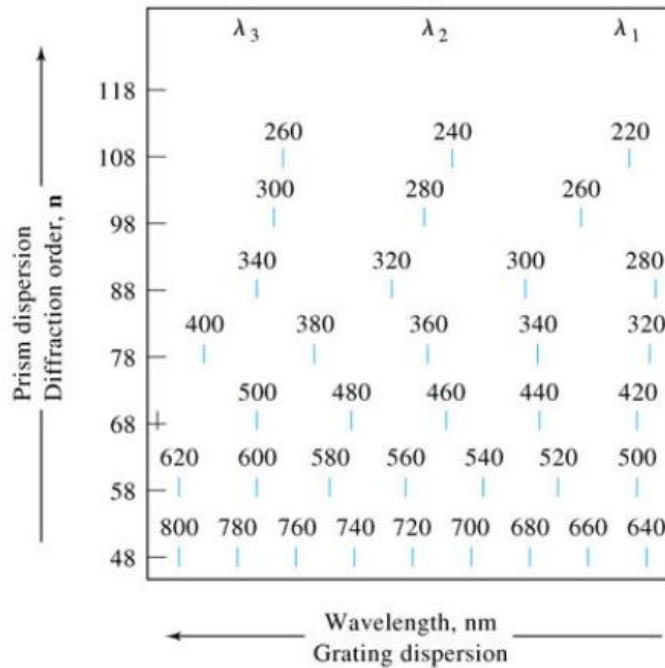
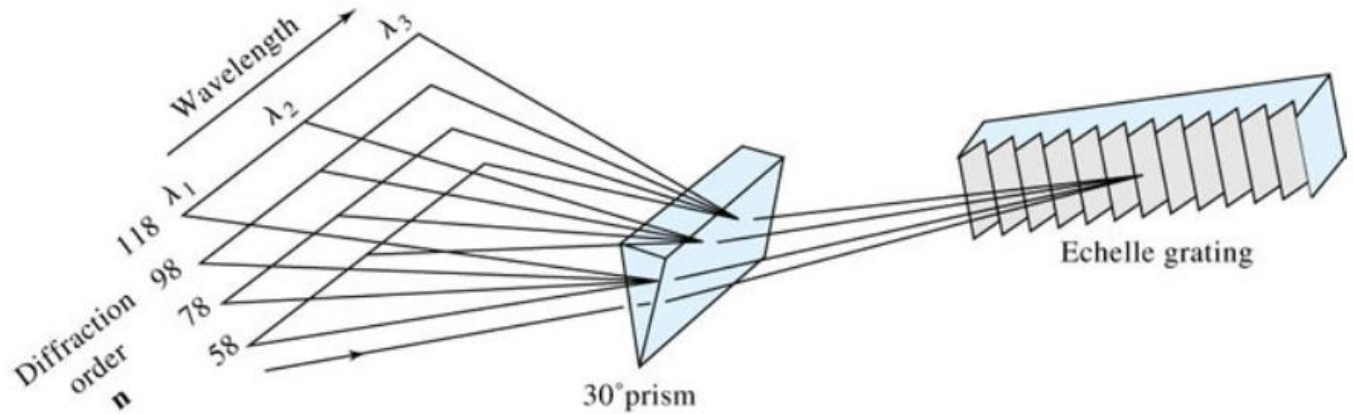

Monochromator Performance Characteristics

1. Spectral purity
2. Dispersion of grating (D)
Reciprocal linear dispersion (D^{-1})
3. Resolving power ($R = \lambda / \Delta\lambda$)
4. Effective bandwidth ($\Delta\lambda_{\text{eff}}$)
5. Light gathering power (F)
Focal length (f)

Performance Characteristics of Grating MC

Four main properties can assess the performance of grating MC

1. Spectral Purity

If the exiting beam is thoroughly studied, it will always be observed that it is contaminated with small amounts of wavelengths far from that of the instrumental setting. This is mainly due to the following reasons:

- a) Scattered radiation due to presence of dust particulates inside the monochromator as well as on various optical surfaces. This drawback can be overcome by sealing the monochromator entrance and exit slits by suitable windows.*
- b) Stray radiation which is radiation that exits the monochromator without passing through the dispersion element. This problem as well as all other problems related to spurious radiation, including scattering, can be largely eliminated by introducing baffles at appropriate locations inside the monochromator, as well as painting the internal walls of the monochromator by a black paint.*
- c) Imperfections of monochromator components, like broken or uneven blazes, uneven lens or mirror surfaces, etc, would lead to important problems regarding the quality of obtained wavelengths.*

Performance Characteristics of Grating MC

2. Dispersion (D), Reciprocal linear Dispersion (D^{-1}) of grating

- Dispersion is the ability of a monochromator to separate the different wavelengths. The angular dispersion can be defined as the change in the angle of reflection with wavelength:

$$\text{Angular dispersion} = dr/d\lambda$$

We have previously seen that:

$$n\lambda = d(\sin i + \sin r)$$

- A widely used parameter for expressing the dispersion of grating monochromators is the inverse of the linear dispersion. This is called reciprocal linear dispersion, $D^{-1} = 1/D$

$$D^{-1} = d\lambda/Fdr \text{ but we have } dr/d\lambda = n/d \cos r$$

Therefore, one can write:

$$D^{-1} = d \cos r/nF$$

At small reflection angles ($<20^\circ$) $\cos r$ approximates to unity which suggests that: $D^{-1} = d/nF$ or $D = nF/d$

3. Resolving Power of MC

- The ability of a grating monochromators to separate adjacent wavelengths, with very small difference, is referred to as the resolving power of the grating monochromator, R.

$R = \lambda/\Delta\lambda$ where:

$\Delta\lambda$ is the difference between the two adjacent wavelengths ($\lambda_2 - \lambda_1$) and λ is their average $(\lambda_1 + \lambda_2)/2$

- The resolving power can also be defined as:

$$R = nN$$

Where n is the diffraction order and N is the number of illuminated blazes. Therefore, better resolving powers can be obtained for:

- Longer gratings.
- Higher blaze density.
- Higher order of diffraction

4. Light Gathering Power of MC

- The ability of a grating monochromator to collect incident radiation from the entrance slit is very important, as only some of this radiation will reach the detector. The speed or *f/number* is a measure of the ability of the monochromator to collect incident radiation.

$$f = F/d$$

- Where; F is the focal length of the collimating mirror or lens and d is its diameter. The light gathering power of a grating monochromator increases as the inverse square of the *f/number*. Thus an $f/2$ mirror gathers 4 times more light than an $f/4$.

$$f(1) / f(2) = (f/number(2))^2 / (f/number(1))^2$$

The *f/number* for most monochromators ranges from 1 to 10.

TABLE 7-1 Comparison of Performance Characteristics of a Conventional and an Echelle Monochromator

| | Conventional | Echelle |
|---|---------------------|----------------|
| Focal length | 0.5 m | 0.5 m |
| Groove density | 1200/mm | 79/mm |
| Diffraction angle, β | 10°22' | 63°26' |
| Order n (at 300 nm) | 1 | 75 |
| Resolution (at 300 nm), $\lambda/\Delta\lambda$ | 62,400 | 763,000 |
| Reciprocal linear dispersion, D^{-1} | 16 Å/mm | 1.5 Å/mm |
| Light-gathering power, F | $f/9.8$ | $f/8.8$ |

Monochromator Slits

- A slit is machined from two pieces of metal to give sharp edges that are exactly aligned (same plane) and parallel
- Since the effective bandwidth of a monochromator is dependent on its dispersion ($D_{\text{eff}} = wD^{-1}$) and the slit width, careful choice of the slit width must be done
- A narrower slit should be preferred for best wavelengths resolution. However, as the slit width gets narrower, the radiant power reaching the detector will decrease, which is too **bad for quantitative analysis**. Overall, adjustment of the slit width is a compromise between detectability and resolution

Effect of Slit width on MC Resolution

Effective bandwidth

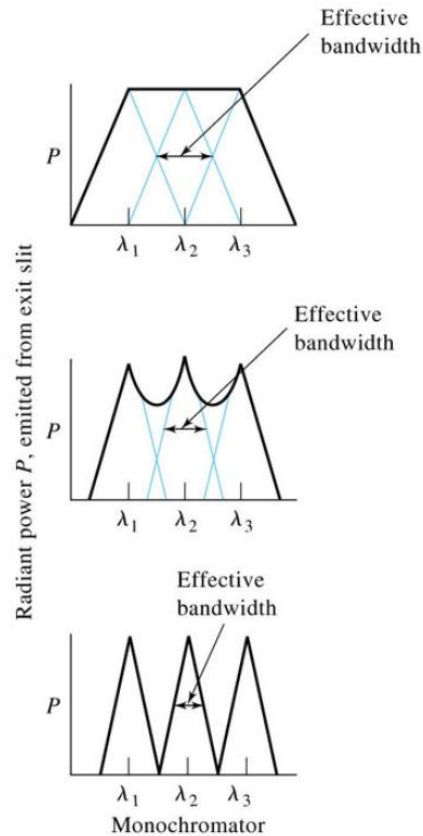
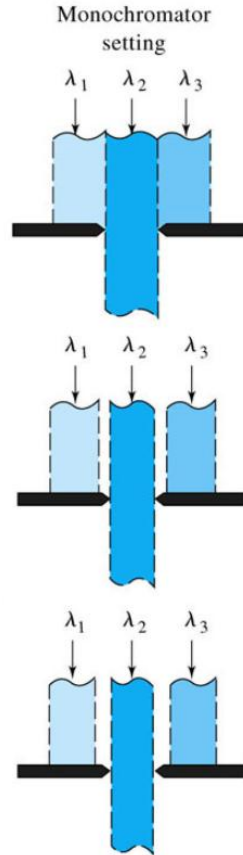
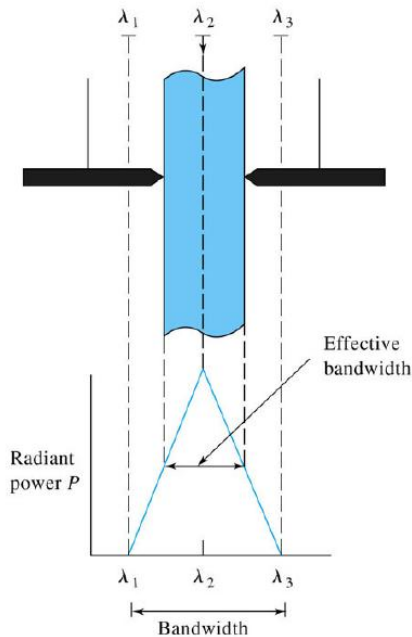

The effect of the slit width on spectra. The entrance slit is illuminated with λ_1 , λ_2 , and λ_3 only. Entrance and exit slits are identical. Plots on the right show changes in emitted power as the setting of monochromator is varied.

Complete resolution of two features only possible when slit is adjusted to produce effective bandwidth half (or less) of difference between λ 's

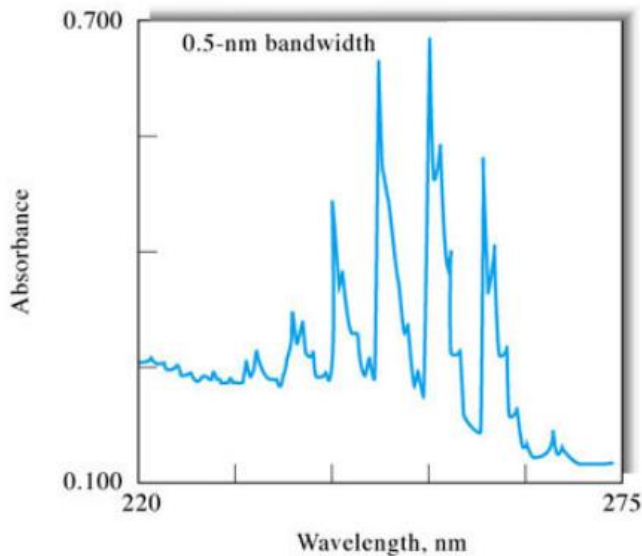

(a)

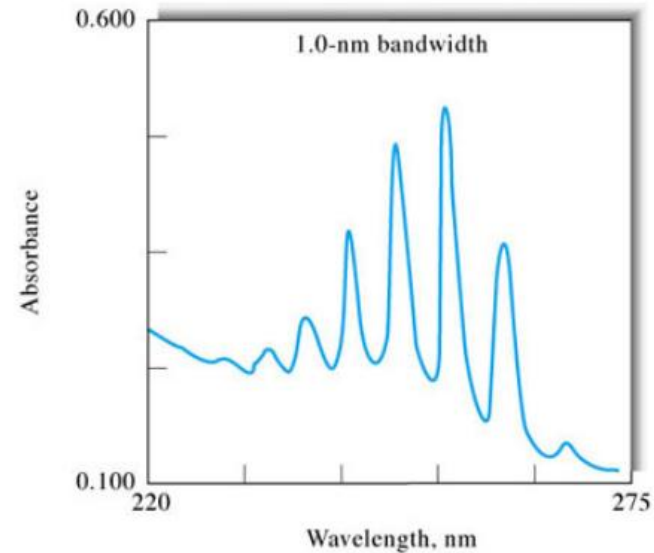

(b)

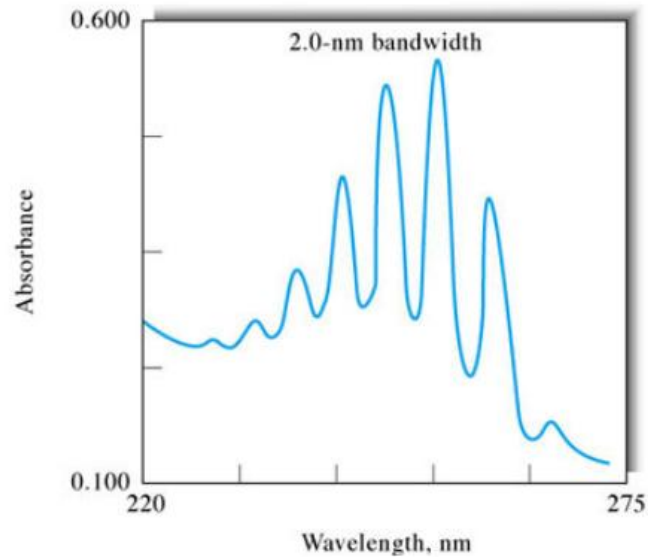

FIGURE 7-26 Effect of bandwidth on spectral detail for benzene vapor: (a)0.5 nm, (b) 1.0 nm, (c)2.0 nm. (From V,A. Kohler,*Amer. Lab.*, 1984, 11,132. Copyright 1984 International Scientific Communications Inc. Reprinted with permission.)

Sample Containers and Optics

- The cells or cuvettes that hold the samples must be made of material that is transparent to radiation in the spectral region of interest.
- Quartz or fused silica is required for work in the ultraviolet region (below 350 nm), both of these substances are transparent in the visible region.
- Silicate glasses can be employed in the region between 350 and 2000 nm.
- Plastic containers can be used in the visible region.
- Crystalline NaCl is the most common cell windows in the IR region.

Radiation Transducers:

The detectors for early spectroscopic instruments were the human eye or a photographic plate or film. Nowadays more modern detectors are in use that *convert radiant energy into electrical signal*.

What do we want in a transducer? Ideal transducer

- High sensitivity
- High S/N (low noise)
- Constant response over many λ 's (wide range of wavelength)
- Fast response time
- $S = 0$ if no light present (low dark current)
- Signal $\propto P$ (where $P =$ radiant power)
- Rugged, cheap and simple

Detector types

- Photon transducers:
- Thermal transducers:

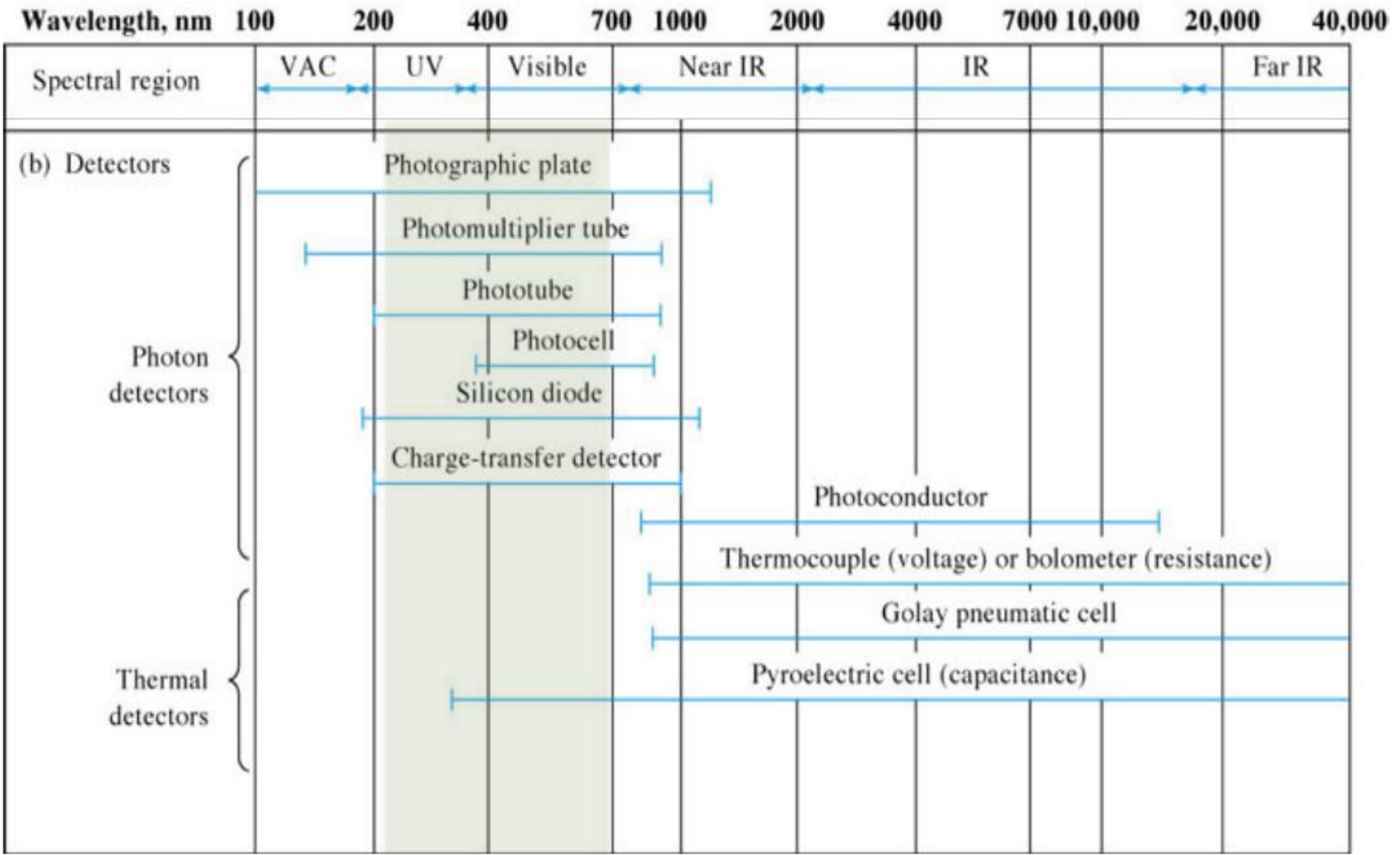

Photon Transducers:

- *Respond to incident photon rate*
- *Highly variable spectral response (determined by photosensitive material)*
- *Respond quickly (microseconds or faster)*
- *Single or multi channel (1-D or 2-D)*
- *Used largely for measurement of UV-Vis radiation*
- *Phototransducers are not applicable in infrared because photons in this region lack the energy to cause photoemission of electrons.*
- *Photon transducers are:*
 - *photovoltaic cells,*
 - *phototubes,*
 - *photomultiplier tubes,*
 - *photoconductivity transducers,*
 - *silicon photodiodes,*
 - *charge-transfer transducers*

Photon Transducers:

Photovoltaic cells:

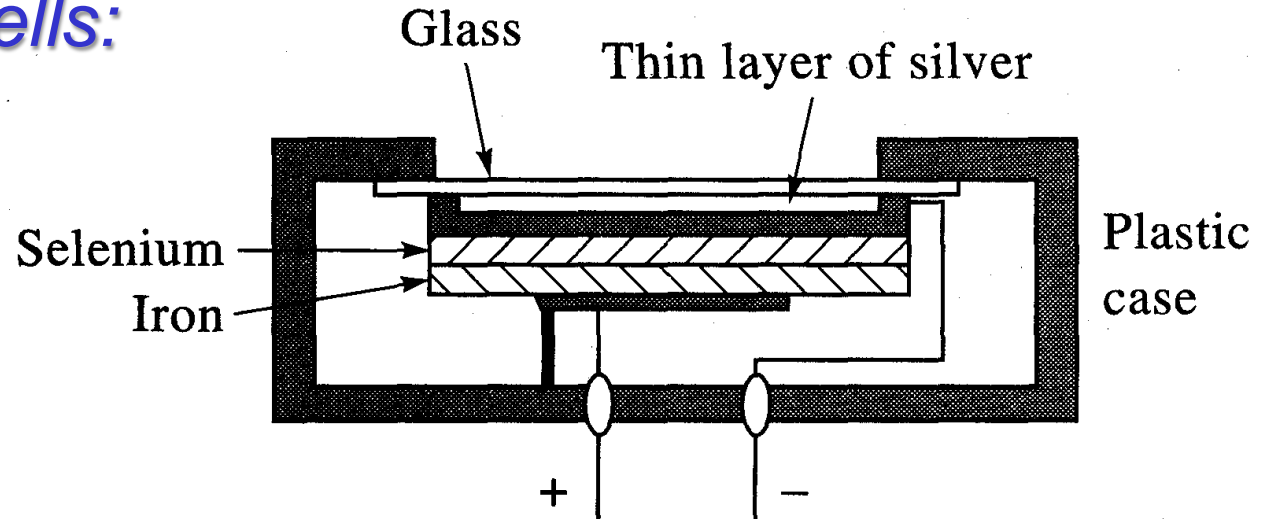

- Simple device that is used for detecting radiation in the visible range
- Consisted of metal-semiconductor-metal sandwiches (Fe-Se-Ag) that produce current when irradiated with (350-750 nm) radiation
- Current produced at the interface of a semiconductor layer and a metal is proportional to the number of photons that strike the semiconductor surface.

Photon Transducers:

Phototubes:

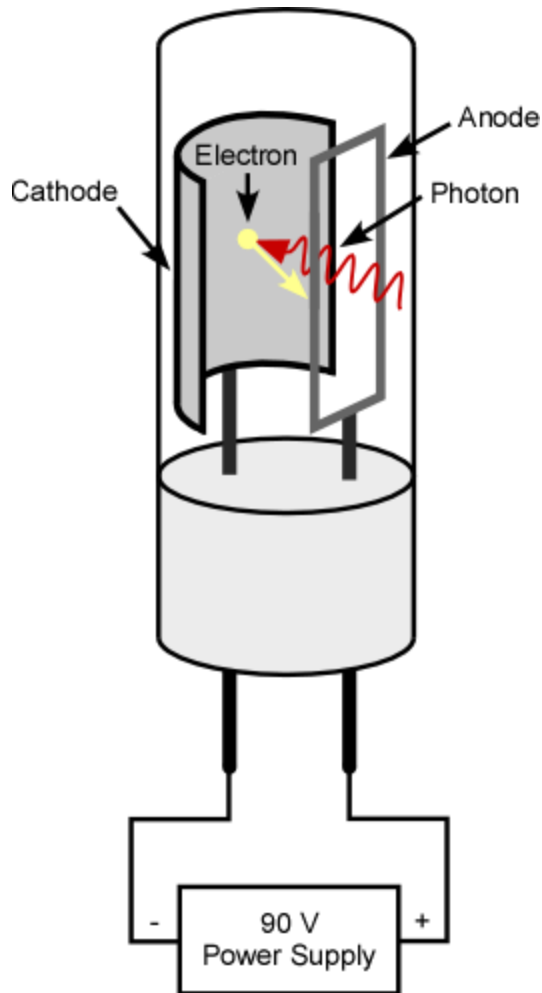

- Consisted of a semicylindrical cathode (that can readily give electrons when it is irradiated) and an anode sealed inside an evacuated transparent envelope
- When a voltage (90 V dc) is applied across the electrodes, emitted electrons flow to the anode generating a photocurrent
- Photocathode surfaces can be bialkali or multialkali metals: Na/K/Cs/Sb. Wavelength response depends on cathode material (200-1000 nm)
- Current produced is proportional to the number of photons that strike the semiconductor surface when the saturation voltage is achieved (90 V)

Photon Transducers: Photomultiplier Tube PMT

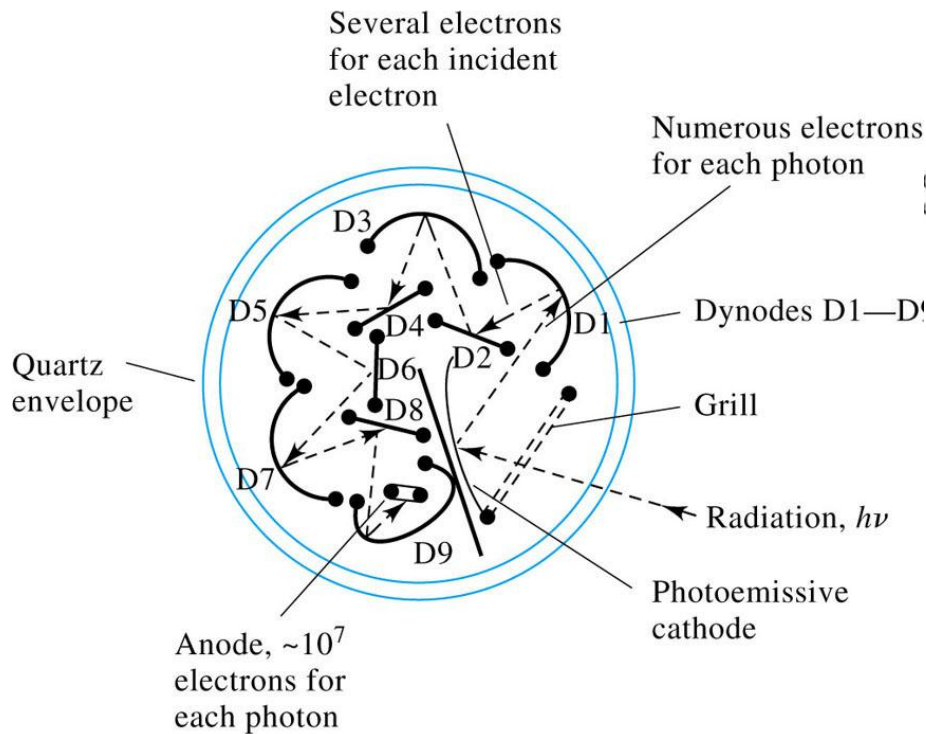

(b)

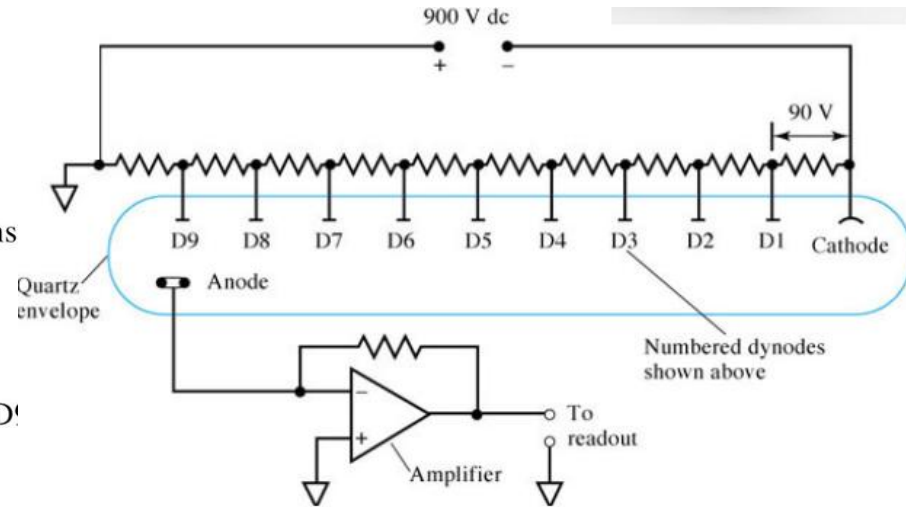

- ✓ The photocathode surface is similar in composition to that of the phototubes, however, PMT's are more developed version of vacuum phototubes
- ✓ irradiation of photoemissive cathode produces electrons, and series of anodes (dynodes) increases gain to 10^6 - 10^7 electrons per photon.

PMT-cont'd

- *Extremely sensitive (used for low light applications).*
- *Light strikes photocathode, several electrons per photon are emitted ($\sim 10^6 - 10^7$ electrons collected at the anode)*
- *Bias voltage applied (900 V), electrons emitted towards a more positive dynode than photocathode (electrons attracted to it), each electron causes emission of several electrons.*
- *These electrons are accelerated towards dynode #2 (90 V more positive than dynode # 1) ...etc., this process continues for 9 dynodes*
- *Result is the flow of electrons $\sim 10^6 - 10^7$ electrons collected at the anode.*
- *Is there a drawback? Sensitivity usually limited by dark current.*
- *Dark current = current generated by thermal emission of electrons in the absence of light.*
- *Thermal emission can be reduced by cooling.*
- *Under optimal conditions, PMTs can detect single photons.*
- *Only used for low-light applications; it is possible to fry the photocathode.*

Photon Transducers:

Silicon Photodiode Transducers

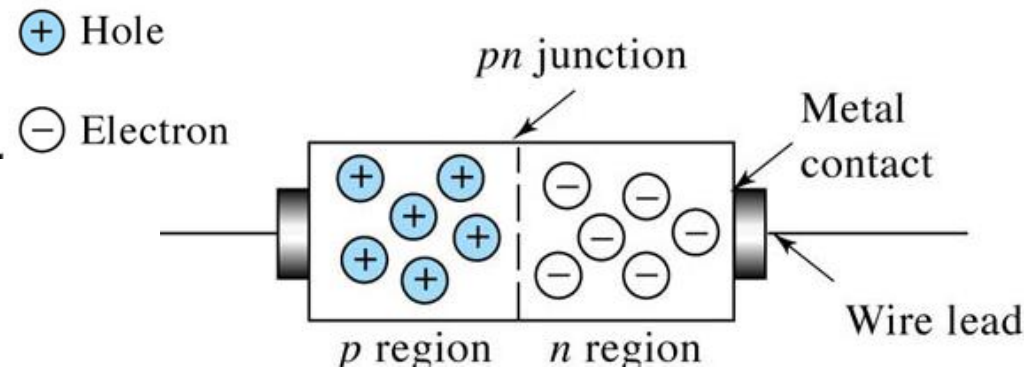

- ✓ Consists of a reverse biased pn junction formed on a silicon chip
- ✓ the reverse bias creates a depletion layer that reduces the conductance of the junction to nearly zero.

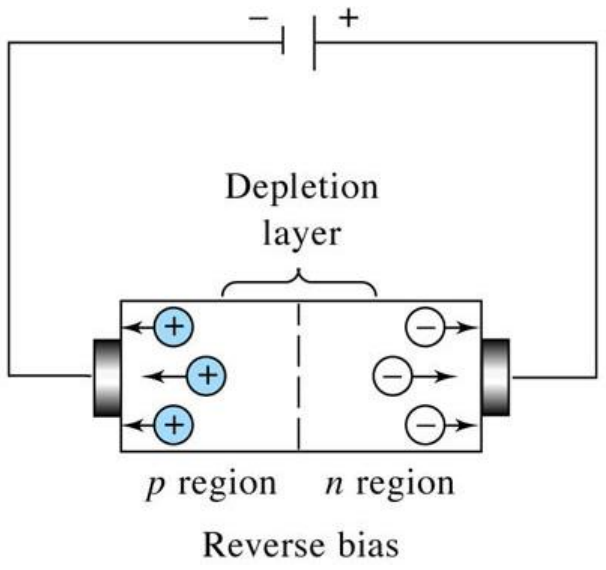

- ✓ If radiation impinges on the chip, however, holes and electrons are formed in the depletion layer and swept through the device to produce a current that is proportional to radiant power.
- ✓ They require only low-voltage power supplies or can be operated under zero bias and so can be used in portable, battery-powered instruments.
- ✓ more sensitive than vacuum phototubes but less sensitive than photomultiplier tubes. Spectral ranges from about 190 to 1100 nm.

Multichannel Photon Transducers

- Modern multichannel transducers consist of an array of small photosensitive elements arranged either linearly or in a two-dimensional pattern on a single semiconductor chip.
- The chip, which is usually silicon and typically has dimensions of a few millimeters on a side, also contains electronic circuitry to provide an output signal from each of the elements either sequentially or simultaneously.
- For spectroscopic studies, a multichannel transducer is generally placed in the focal plane of a spectrometer so that various elements of the dispersed spectrum can be transduced and measured simultaneously.
- Three types of multichannel devices are used in commercial instruments
 - *photodiode arrays (PDAs),*
 - *charge-injection devices (CIDs),*
 - *charge-coupled devices (CCDs).*

Multichannel Photon Transducers

Photodiode arrays (PDA)

- these are simply linear arrays of silicon diodes, each consists of a reverse-biased pn junction. The number of linear diodes used in each photodiode array varies between 64 to 4096 with 1024 silicon diodes as the most common.
- Each element consists of a diffused p-type bar in an n-type silicon substrate to give a surface region that consists of a series of side-byside elements that have typical dimensions of 2.5 by 0.025 mm.
- In using a diode-array transducer, the slit width of the spectrometer is usually adjusted so that the image of the entrance slit just fills the surface area of one of the diodes that make up the array.

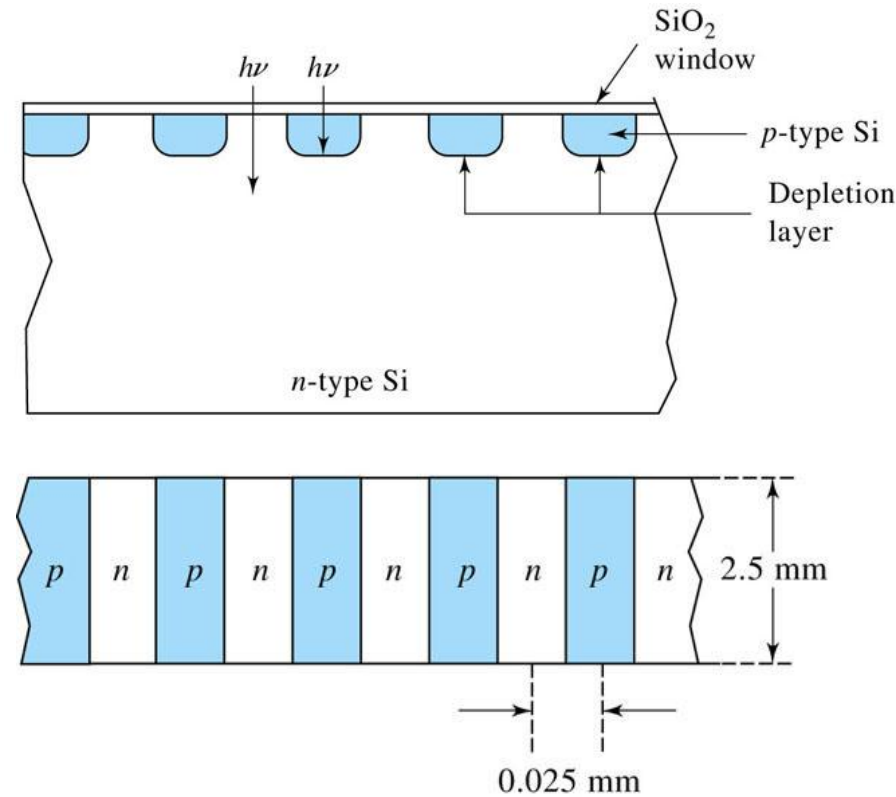

PDA's cannot match the performance of PMT's wrt sensitivity, dynamic range, and signal-to-noise ratio. Thus, they have been used for applications in which high sensitivity and large dynamic range is not needed, such as in absorption spectrometry.

Multichannel Photon Transducers

Charge-Transfer Devices:

- charge-injection devices (CIDs),*
- charge-coupled devices (CCDs)*

- ✓ CTDs operate like a photographic film in the sense that they integrate signal information as radiation strikes them.*
- ✓ The charges developed in a Si-crystal as a result of absorption of photons are collected and measured*

- The performance characteristics of CTDs approach or sometimes surpass those of PMTs in addition to having the multichannel advantage*
- CTDs offer great sensitivity and high resolution to low light detection.*

Charge-Transfer Device (CTD)

- Important for multichannel detection (i.e., spatial resolution); 2-dimensional arrays.
- Sensitivity approaches PMT.
- An entire spectrum can be recorded as a “snapshot” without scanning.
- Integrate signal as photon strikes element.
- Each pixel: two conductive electrodes over an insulating material (e.g., SiO_2).
- Insulator separates electrodes from n-doped silicon.
- Semiconductor capacitor: stores charges that are formed when photons strike the doped silicon.
- $10^5 - 10^6$ charges/pixel can be stored (gain approaches gain of PMT).
- How is amount of charge measured?
 - Charge-injection device (CID): voltage change that occurs from charge moving between electrodes.
 - Charge-coupled device (CCD): charge is moved to amplifier.

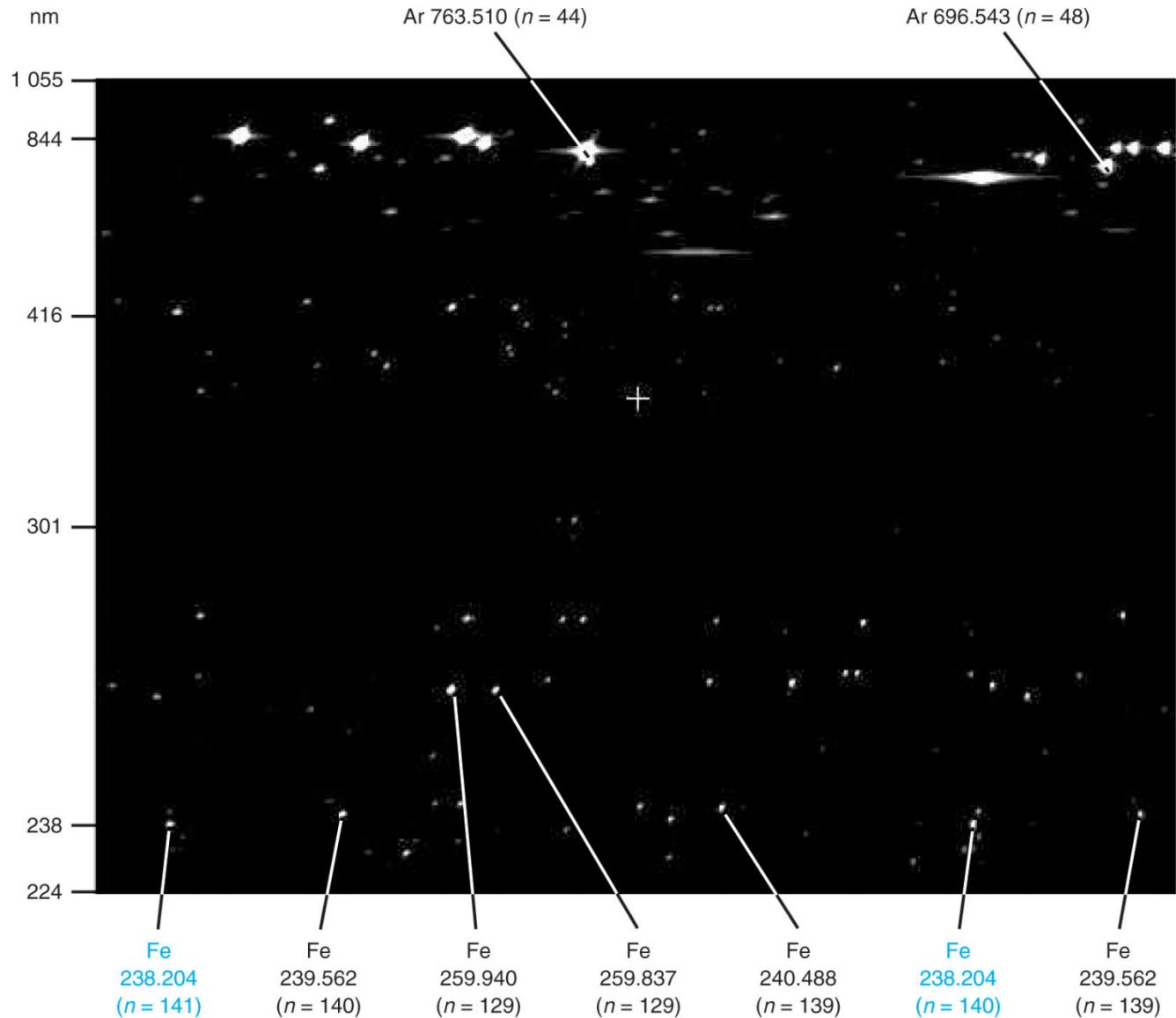

FIGURE 20-18 “Constellation image” of inductively coupled plasma emission from 200 µg Fe/mL seen by charge injection detector. Almost all peaks are from iron. Horizontally blurred “galaxies” near the top are Ar plasma emission. A prism spreads wavelengths of 200–400 nm over most of the detector. Wavelengths >400 nm are bunched together at the top. A grating provides high resolution in the horizontal direction. Selected peaks are labeled with wavelength (in nanometers) and diffraction order (n in Equation 19-1) in parentheses. Two Fe peaks labeled in color at the lower left and lower right are both the same wavelength (238.204 nm) diffracted into different orders by the grating. [Courtesy M. D. Seltzer, Michelson Laboratory, China Lake, CA.]

Thermal Transducers:

- ✓ *Photon transducers are generally not applicable in the infrared because photons in this region lack the energy to cause photoemission of electrons. Thus, thermal transducers or photoconductive transducers must be used.*
- ✓ *In thermal transducers, the radiation impinges on and is absorbed by a small blackbody and the temperature rise is measured.*
- ✓ *Respond to incident energy rate (average power)*
- ✓ *Sense the change in temperature that is produced by the absorption of incident radiation*
- ✓ *Relatively flat spectral response curves (determined by window and coating)*
- ✓ *Respond slowly (milliseconds or slower)*
- ✓ *Single channel (1-D)*
- ✓ *Used largely for measurement of IR radiation*
- ✓ *Thermal noise is an issue, housing in a vacuum, shielding and cooling may be required.*
- ✓ *Types are: Thermocouples,
 Bolometer,
 Pyroelectric transducers*

Thermal Transducers:

Thermocouples:

- called “ Junction thermometers “
- A thermocouple consists of a pair of junctions formed when two pieces of a metal such as copper are fused to each end of a dissimilar metal such as constantan and iron as shown in Figure. A voltage develops between the two junctions that varies with the difference in their temperatures.
- A well designed thermocouple is capable of responding to temperature difference of 10^{-6} K.
- Cheap, slow, insensitive.

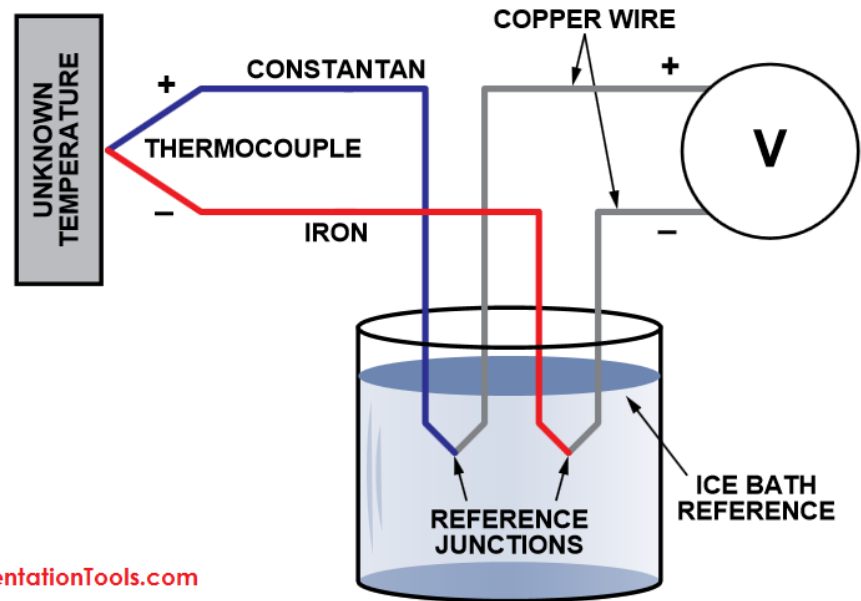

Thermal Transducers:

Bolometers:

- called “resistance thermometers”
- constructed of strips of metals, such as platinum or nickel or of a semiconductor. Semiconductor bolometers are often called *thermistors*.
- These materials exhibit a relatively *large change in resistance as a function of temperature*. The responsive element is kept small and blackened to absorb radiant heat.
- Bolometers *are not so extensively used* as other infrared transducers for the mid-infrared region. However, a germanium bolometer, operated at 1.5 K, is nearly an ideal transducer for radiation in the 5 to 400 cm^{-1} (2000 to 25 μm) range.

Highly sensitive

Thermal Transducers: Pyroelectric Transducers:

- *Pyroelectric transducers are constructed from single crystalline wafers of pyroelectric materials, which are insulators (dielectric materials) with very special thermal and electrical properties.*
- *Triglycine sulfate $(\text{NH}_2\text{CH}_2\text{COOH})_3\cdot\text{H}_2\text{SO}_4$, (usually deuterated or with a fraction of the glycines replaced with alanine), is the most important pyroelectric material used in the construction of infrared transducers.*
- *When an electric field is applied across any dielectric material, electric polarization takes place whose magnitude is a function of the dielectric constant of the material. For most dielectrics, this induced polarization rapidly decays to zero when the external field is removed. Pyroelectric substances, in contrast, retain a strong temperature-dependent polarization after removal of the field. Thus, by sandwiching the pyroelectric crystal between two electrodes (one of which is infrared transparent) a temperature-dependent capacitor is produced. Changing its temperature by irradiating it with infrared radiation alters the charge distribution across the crystal, which creates a measurable current in an external electrical circuit that connects the two sides of the capacitor. The magnitude of this current is proportional to the surface area of the crystal and to its rate of change of polarization with temperature.*
- *Pyroelectric transducers exhibit **response times that are fast enough** to allow them to track the changes in the time-domain signal from an interferometer. For this reason, most Fourier transform infrared spectrometers use this type of transducer.*

Signal Processors and Readouts

The signal processor is ordinarily an electronic device that amplifies the electrical signal from the transducer. In addition, it may alter the signal from dc to ac (or the reverse), change the phase of the signal, and filter it to remove unwanted components. Furthermore, the signal processor may be called upon to perform such mathematical operations on the signal as differentiation, integration, or conversion to a logarithm.