



Topics 1. Manipulators and robots

Analysis and Manufacturing of 6 DoF Hybrid Robot Manipulator for Teleoperation in Medical Applications

Erkin GEZGİN

Izmir Katip Celebi University

Department of Mechatronics Engineering, Turkey

E-mail: erkin.gezgin@ikc.edu.tr

Abstract

Parallel to the rapidly developing technology, robot manipulators, whose areas of usage have continuously been expanded from the last periods of past century, have been took part in many different successful applications. Thanks to its increasing significance, nowadays medical science is one of the primary areas of those applications. Thus, this study targets mainly the field of medical science. Within the scope of this paper, six degrees of freedom hybrid robot manipulator with large workspace and adequate precision was introduced and equipped with dual actuators in its two Cartesian axes for possible haptic integration for the future. Target hybrid manipulator was designed in such a way that it can be used in various related medical applications such as teleoperations in robotic surgery, surgical navigation, dental and laparoscopic simulations. After the structural design part was completed, direct and inverse kinematic analysis procedures were carried out and by using rapid prototyping techniques the manipulator was manufactured.

Keywords: Hybrid Robot Manipulators, Teleoperation, Kinematic Analysis.

1. Introduction

By the help of robot manipulators, wide ranges of robotic applications that are capable of haptic feedback from virtual or distant environments are continuously increasing in many areas for various user profiles. While utilizing novel algorithms in haptic control provide life like feedbacks, new manipulator designs offer larger workspaces and increased manipulation precision. Although related studies in the literature are mostly focused on control parts of the issue, design of a capable robot manipulator with sufficient degrees of freedom for predefined workspaces with respect to the given tasks and constraints should not be left unattended as it constitutes the most important part in this research area.

Wayne et al. [1] surveyed three different control

algorithms that are related to the haptic manipulators in terms of interactions between humans and robotic devices and introduced their comparisons with each other. In their study authors created a bridge between the old and current developing control algorithms to emphasize the rapid development in the related literature. Hyung et al. [2] started their study by considering the negative effects of singularities in parallel manipulators on the haptic systems. In the light of their research, they proposed four task based and redundant control algorithms for the singularity problems of six degrees of freedom parallel haptic manipulator with four sub chains that was also designed by them. Also they compared the results of their algorithms in a simulation environment. Erwin et al. [3] designed force controlled haptic planar manipulator for the movement control analysis of human arm. In their study they reduced the contact instability problem by using servo based control system on the lightweight but stiff manipulator. Their manipulator and the controller design were tried on a subject that performs a position based task and the results were introduced. Schouten et al. [4] designed a torque controlled manipulator with haptic controller to specify the dynamics of human wrist joint. In their study the dynamics of the human wrist joint and effects due to neurological dysfunctions were measured under virtual conditions. Dede et al. [5] designed six degrees of freedom haptic hybrid robot manipulator that is capable of displaying point type contact. Authors reconfigured the R-Cube manipulator for the translational part of the system in terms of dimensions and orientations in order to comply with the requirements of the haptic system design criteria. The most important merits of the system are introduced as its compactness and high stiffness. In their study authors also presented the integration of the hybrid manipulator mechanism with control interface. Ryu et al. [6] designed six degrees of freedom modular manipulator in order to control a mobile system by means of teleoperation. Their introduced design has dual parallel manipulators with individual three degrees of freedom that are attached each other to form six degrees of freedom modular manipulator system. The

system is capable to be used in the control of both planar and spatial tasks in various applications by utilizing only the necessary actuators and the manipulator section to reduce the CPU loads during calculations. Pinskiar et al. [7] proposed a flexure based haptic enabled modular manipulator for micromanipulation tasks. In their study they investigated and verified the performance of an experimental 2 degrees of freedom configuration. Tian et al. [8] introduced the design of six degrees of freedom precision positioning system that was formed by the assembly of dual three degrees of freedom individual systems operated by piezoelectric actuators. In their study motion with high precision capability was obtained.

After the investigation of brief literature survey, it can be easily seen that, usage of robot manipulators for various fields are increasing. Throughout the literature, each study has tried to overcome the mechanical and software constraints by proposing new manipulator designs along with new control schemes to achieve precise, comfortable and efficient manipulation. Considering the advances in the field, this study tries to introduce six degrees of freedom new hybrid manipulator design that is formed by the assembly of three degrees of freedom serial spherical and three degrees of freedom parallel Cartesian manipulators for the medical applications. Cartesian part of the manipulator is modified by considering R-Cube [9] Cartesian parallel manipulator design in order to decrease the total number of dyads to achieve small footprint and comfortable manipulation in its workspace. While the semi-decoupled nature of the manipulator renders kinematic analysis problems to be solved easier, it also provides easy solutions to control problems. Although the study does not cover haptic feedback control, the manipulator is equipped with two actuators for future haptic integration. Throughout the study, structural design of the manipulator was introduced along with its direct and inverse kinematic analysis tasks. Also the manufacturing steps were shown along with the first manipulator prototype.

2. Structural Design and Synthesis

As mentioned in previous section the main aim of this study is to design a robot manipulator that will be used for the teleoperation tasks in medical applications such as robotic surgery, surgical navigation, dental and laparoscopic simulations. In the light of this aim, prior to the structural synthesis, design constraints of the task were specified as below.

- The end effector of the robot manipulator should be capable of mimicking all of the rigid body motions in space to ensure adequate teleoperation control.
- In order to utilize the robot manipulator for various different tasks, its overall workspace should be large and singularity free.

- Kinematic structure of the robot manipulator should be able to adapt various different applications without any modifications.
- Structure of the manipulator should be as simple as possible to render the kinematic analysis and control tasks easier.
- As the manipulator will be utilized for medical applications, it should have a structure that provides an adequate precision.

Considering the criterions above, structure of the manipulator was determined to be hybrid. The overall system was decided to be designed in a way that three degrees of freedom Cartesian parallel manipulator section is responsible for translations while its three degrees of freedom serial spherical manipulator section is responsible for orientations. Thus the overall degrees of freedom become six. In order to fulfil the design constraints in Cartesian space, structure of the R-Cube parallel manipulator was modified so that Cartesian part of the final manipulator has two dyads instead of three. Although removing the dyad that is responsible for the z translation from the manipulator cancelled its decoupled motion in z axis, the hybrid manipulator gained a larger workspace and a smaller footprint (Figure 1-2). In accordance with the possible haptic integration for future, the manipulator was equipped with dual actuators that are responsible for decoupled x and y translations. Moreover to be able to inspect z translation, single encoder was attached to one of the dyads.

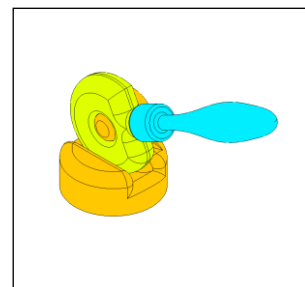

While it is clear that, the serial part of the hybrid manipulator is three degrees of freedom, the mobility of the Cartesian section can be calculated by using the formulation [10] introduced below for the Cartesian manipulators.

$$M = (\lambda + 3) + \sum_{i=1}^{c_i} (d_i - D) + \sum_{i=1}^{c_i} (f_i - \lambda_i) + q - j_p \quad (1)$$

Where in equation 1, λ is the space or subspace number, D is the dimension of the vectors in Cartesian space, d_i represents the dimensions of the vectors on the

subspaces of the structural groups on the related leg, f_i is the total degrees of freedom of all joints in related leg, q is the number of excessive links, j_p is the number of passive degrees of freedoms, and C_i is the total number of legs. If the variables of this mobility equation are evaluated with respect to the designed manipulators Cartesian section, the mobility will be calculated as three.

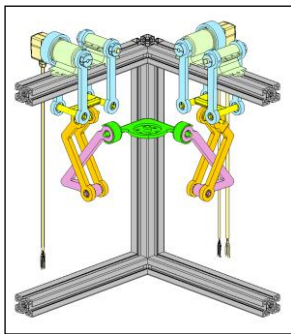

Fig. 1. a) Three Degrees of Freedom Serial Spherical Manipulator Responsible for Orientations, b) Three Degrees of Freedom Cartesian Manipulator Responsible for Orientations

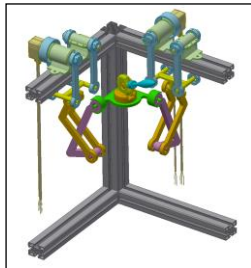

Fig. 2. Designed Six Degrees of Freedom Hybrid Robot Manipulator

$$M = (4 + 3) + (2 - 3) + (2 - 3) + (7 - 5) + (7 - 5) + 0 - 6 = 3$$

When the overall hybrid manipulator is considered, it can easily be seen that the kinematic structure of the manipulator consists of three closed loops, 17 revolute joints, and 15 links including the ground (Figure 3).

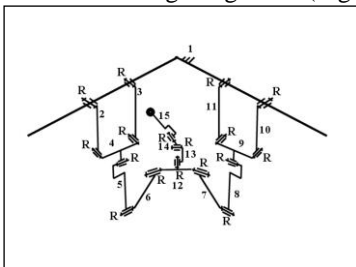

Fig. 3. Simple Kinematic Structure of Designed Hybrid Manipulator

3. Kinematic Analysis

This section is devoted to the direct and inverse kinematic analysis of the proposed hybrid manipulator. As the kinematic analysis of serial spherical section is straight forward and known, only Cartesian part of the manipulator will be considered.

3.1. Direct Task

Section view of the Cartesian part of the hybrid manipulator from the x-z plane is shown in figure 4 by revealing all its construction parameters and variables. Point P on the platform is taken so that it locates at the intersection of the three revolute axis of the serial spherical manipulator section.

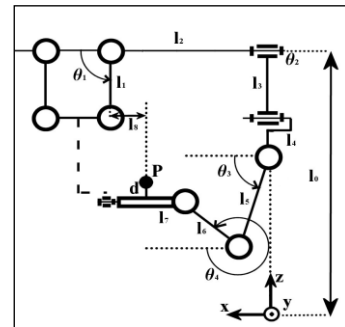

Fig. 4. Section View of the Cartesian Part of The Hybrid Manipulator from the x-z Plane

As the translations on x and y axes are decoupled, the x and y coordinates of the P point on the platform can be easily calculated by the equations below.

$$\begin{aligned} P_x &= l_2 + l_1 \cos \theta_1 - l_8 \\ P_y &= l_2 - l_3 \cos \theta_2 - l_8 \end{aligned} \quad (2)$$

It can be easily seen from the equation 2 that x and y coordinates of the point P on the platform depends only the variable angles θ_1 and θ_2 respectively. However, due to the modified Cartesian part, z coordinate of point P should be calculated in a more complex manner.

$$P_z = l_0 - (l_3 \sin \theta_2 + l_4 + l_5 \sin \theta_3 + l_6 \sin \theta_4 - d) \quad (3)$$

As seen in equation 3, z coordinate of the point P on the platform depends on four individual variable angles ($\theta_1, \theta_2, \theta_3, \theta_4$), yet as the Cartesian section of the manipulator has three degrees of freedom, one of the dependent variables should be eliminated from the equation. From this point of view in order to eliminate the selected parameter θ_1 from the equation 3, x coordinate of



the point P will be written in another form.

$$P_x = l_5 \cos \theta_3 + l_6 \cos \theta_4 + l_7 \quad (4)$$

When the x coordinates of point P in equation 2 and 4 are equalized,

$$\cos \theta_4 = K_1, \quad K_1 = \frac{(l_2 + l_1 \cos \theta_1 - l_8 - l_5 \cos \theta_3 - l_7)}{l_6} \quad (5)$$

equation 5 will be obtained. Also by using equation 3,

$$\sin \theta_4 = A_1 - K_2, \quad A_1 = -\frac{P_z}{l_6}, \quad (6)$$

$$K_2 = \frac{(-l_0 + l_3 \sin \theta_2 + l_4 + l_5 \sin \theta_3 - d)}{l_6}$$

equation 6 can be written as above. If the squares of the equation 5 and 6 are taken and added together side by side,

$$A_1^2 - 2K_2 A_1 + K_3 = 0, \quad K_3 = K_1^2 + K_2^2 - 1 \quad (7)$$

equation 7 without the dependent variable θ_4 will be obtained. If the quadratic equation is solved for the parameter A_1 ,

$$A_{1,1}, A_{1,2} = \frac{2K_2 \pm \sqrt{4K_2^2 - 4K_3}}{2} \quad (8)$$

two solutions will be found. Using these solutions, two distinct solutions for the z coordinate of point P can be calculated.

$$P_{z1} = -l_6 A_{1,1} \quad (9)$$

$$P_{z2} = -l_6 A_{1,2}$$

At this point it should be noted that, if the system is being used in the upper section of the workspace, the z coordinate of point P should be taken from the solutions that has the larger value and if the system is being used in the lower section of the workspace, the z coordinate of point P should be taken from the solution that has the smaller value.

3.2. Inverse Task

Similar to the direct task as the translations on x and y axes are decoupled, variable angles θ_1 and θ_2 can be easily calculated by using the given values of x and y coordinates of point P.

$$\theta_1 = \cos^{-1} \frac{P_x - l_2 + l_8}{l_1} \quad (11)$$

$$\theta_2 = \cos^{-1} \frac{P_y - l_2 + l_8}{l_3}$$

In order to find the variable angle θ_3 by using the given value of z coordinate of point P, θ_4 should be eliminated by utilizing the equations 3 and 4.

$$l_6 \sin \theta_4 = R_1 - l_5 \sin \theta_3, \quad R_1 = l_0 + d - l_3 \sin \theta_2 - l_4 - P_z \quad (12)$$

$$l_6 \cos \theta_4 = R_2 - l_5 \cos \theta_3, \quad R_2 = P_x - l_7 \quad (13)$$

When the squares of equation 12 and 13 are taken and added side by side, a single equation is obtained that is dependent on the variable θ_3 .

$$R_1 \sin \theta_3 + R_2 \cos \theta_3 = R_3, \quad R_3 = \frac{R_1^2 + R_2^2 + l_5^2 - l_6^2}{2l_5} \quad (14)$$

If $\cos \theta_3$ is replaced with $\sqrt{1 - \sin^2 \theta_3}$ in equation 14, equation below will be formed.

$$(R_1^2 + R_2^2) \sin^2 \theta_3 - 2R_1 R_3 \sin \theta_3 + (R_3^2 - R_2^2) = 0 \quad (15)$$

Utilizing equation 15, value of $\sin \theta_3$ can be calculated easily.

$$(\sin \theta_3)_{1,2} = \frac{2R_1 R_3 \pm \sqrt{4R_1^2 R_3^2 - 4(R_1^2 + R_2^2)(R_3^2 - R_2^2)}}{2(R_1^2 + R_2^2)} \quad (16)$$

Finally using equation 16, θ_3 can be calculated.

$$(\theta_3)_{1,2} = \sin^{-1} \frac{2R_1 R_3 \pm \sqrt{4R_1^2 R_3^2 - 4(R_1^2 + R_2^2)(R_3^2 - R_2^2)}}{2(R_1^2 + R_2^2)} \quad (17)$$

4. Prototype Manufacturing

After the completion of the kinematic analysis and simulation runs, manufacturing of the hybrid robot manipulator was carried out. All of the links of the designed manipulator was printed by using rapid prototyper that utilizes ABS-Plus material. Also the manipulator frame was constructed by aluminum profiles to reduce the overall weight of the system (Figure 6).

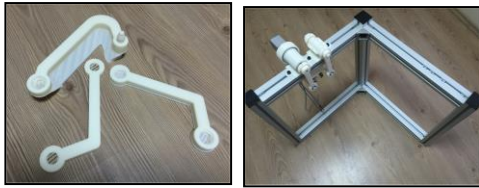

Fig. 6. Manipulator Links that are Printed oh Rapid Prototyper and the Aluminum Manipulator Frame

As mentioned before due to possible haptic feedback integration to the manipulator for future, two of its translation axes were equipped with brushless maxon actuators with hall effect sensors and encoders (Figure 7).



Fig. 7. Brushless Maxon Actuators and the Detail of the Passive Revolute Joint

In order to be able to inspect the z translation of the system single Maxon HEDL-5540 encoder was attached to a joint located on one of the dyads of the manipulator (Figure 8) to measure the variable θ_3 (Figure 4).



Fig. 8. Maxon HEDL-5540 encoder

Overall prototyped hybrid manipulator can be seen in Figure 9 with its Cartesian Part and the attached serial part on the platform.

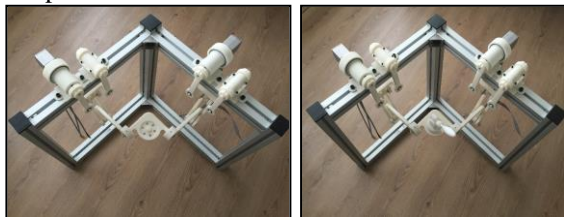

Fig. 9. Prototype of the Hybrid Manipulator

5. Conclusions

Throughout this paper six degrees of freedom hybrid manipulator with large workspace and low footprint was proposed and manufactured for medical applications. Hybrid structure was formed by using three degrees of freedom modified R-Cube Cartesian manipulator for translations and attached on its platform, three degrees of freedom serial spherical manipulator for orientations. The direct and inverse tasks of the Cartesian part of the

proposed manipulator were introduced along with the equations. As the manipulator was equipped with dual brushless actuators in its Cartesian part, possible haptic integration will be considered in future studies.

6. Acknowledgements

This work was supported by the Research Fund of the İzmir Katip Celebi University Project Number: 2013-2-FMBP-08

References

- [1]. Wayne J. Book, Davin K. Swanson, Reach out and touch someone: controlling haptic manipulators near and far, *Annual Reviews in Control* 28 (2004) 87-95.
- [2]. Hyung Wook Kim, Jae Hoon Lee, Il Hong Suh, Byung-Ju Yi, Comparative study and experimental verification of singular-free algorithms for a 6 DOF parallel haptic device, *Mechatronics* 15 (2005) 403-422.
- [3]. Erwin de Vlugt, Alfred C. Schouten, Frans C.T. van der Helm, Piet C. Teerhuis, Guido G. Brouwn, A force-controlled planar haptic device for movement control analysis of the human arm, *Journal of Neuroscience Methods* 129 (2003) 151-168.
- [4]. Alfred C. Schouten, Erwin de Vlugt, J.J. Bob van Hilten, Frans C.T. van der Helma, Design of a torque-controlled manipulator to analyse the admittance of the wrist joint, *Journal of Neuroscience Methods* 154 (2006) 134-141.
- [5]. Bilginca T, Gezgin E., and Dede M.I.C. "Integration of the hybrid-structure haptic interface: HIPHAD v1.0." In *Proceedings of the International Symposium of Mechanism and Machine Theory*, (2010) 267-284.
- [6]. Dongseok Ryu, Jae-Bok Song, Changhyun Cho, Sungchul Kang, Munsang Kim, Development of a six DOF haptic master for teleoperation of a mobile manipulator, *Mechatronics* 20 (2010) 181-191.
- [7]. Joshua Pinski, Bijan Shirinzadeh, Leon Clark, Yanding Qin, Sergej Fatikow, Design, development and analysis of a haptic-enabled modular flexure-based manipulator, *Mechatronics*, <http://dx.doi.org/10.1016/j.mechatronics.2016.10.004>.
- [8]. Cai, Kunhai, Yanling Tian, Fujun Wang, Dawei Zhang, Xianping Liu, and Bijan Shirinzadeh. "Design and control of a 6-degree-of-freedom precision positioning system." *Robotics and Computer-Integrated Manufacturing* 44 (2017) 77-96.
- [9]. Li, Weimin, Feng Gao, and Jianjun Zhang, R-CUBE, a decoupled parallel manipulator only with revolute joints, *Mechanism and Machine theory* 40.4 (2005) 467-473.
- [10]. Alizade, Rasim, Cagdas Bayram, and Erkin Gezgin, Structural synthesis of serial platform manipulators, *Mechanism and Machine Theory* 42.5 (2007) 580-599.